

Thread Turning Inserts

A01

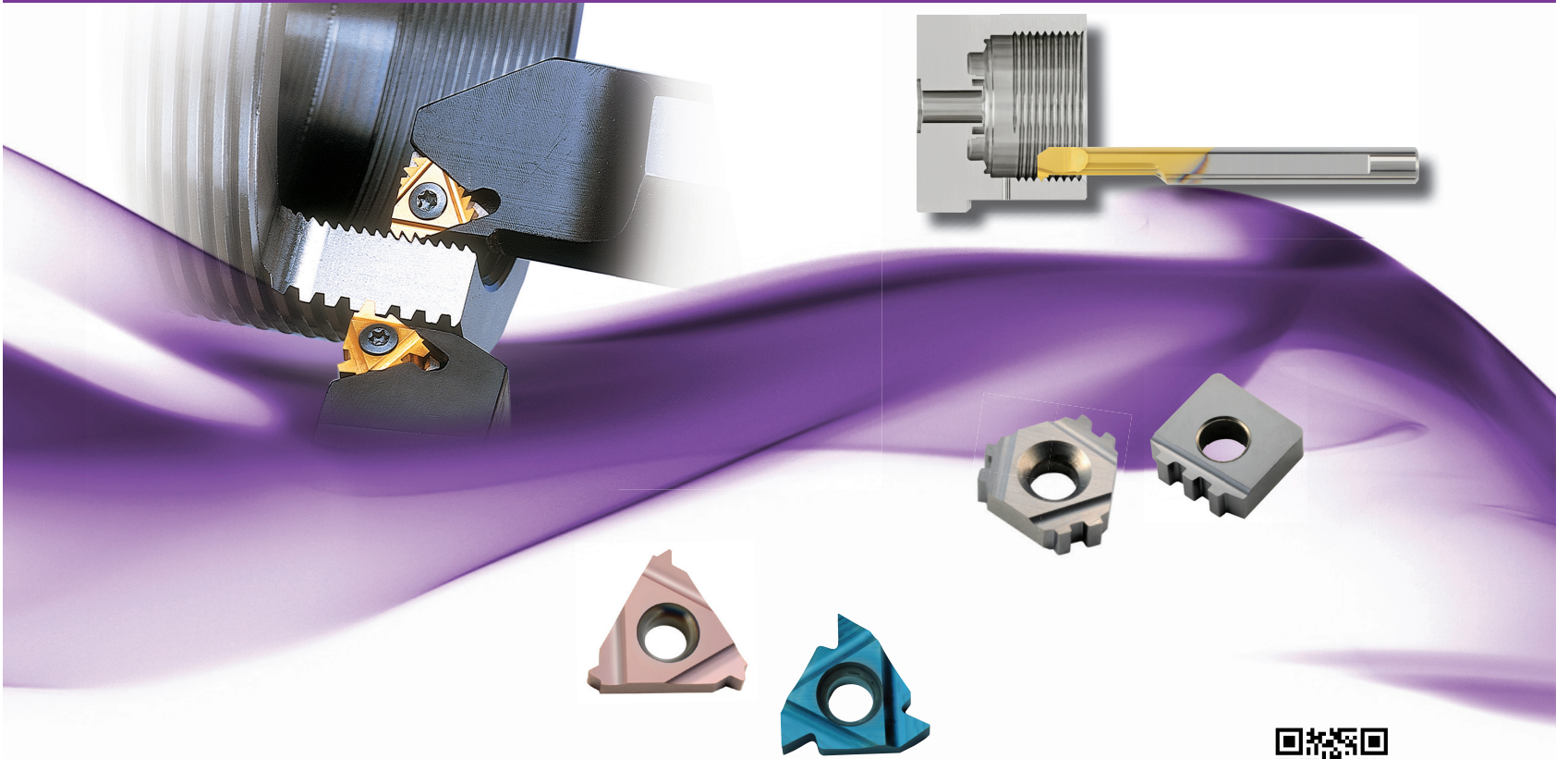

Type B
Demonstration

Contents:	Page:	Contents:	Page:
Product Identification	2	V-0.055	34
Partial Profile 60°	3-4	Extreme - Line Casing	35
Partial Profile 55°	5-6	Buttress Casing	35
ISO - metric	7-9	VAM	35
UN - Unified	10-13	HUGHES	36
Whitworth - 55°	14-17	PAC	36
NPT	18-19	NPS	37
NPTF	20	NPSM	37
BSPT	21-22	Vertical API	38
DIN 477	22	Vertical API Buttress Casing	39
Acme	23	Vertical API Round	40
Stub Acme	24	Chasers API Round	41
Trapez - DIN 103	25	Chasers API Buttress Casing	42
PG - DIN 40430	26	Chasers OTTM Buttress Casing	42
Sagengewinde - DIN 513	26	Chasers API Buttress Casing	43
Round - DIN 405	27	Chasers OTTM Buttress Casing	43
Round - DIN 20400	27	Chasers API Buttress Casing	44
UNJ	28-29	Chasers OTTM Buttress Casing	44
MJ - ISO 5855	30	Large Profile Inserts and Toolholders	45-50
American Buttress	31-32	Large Profile - Acme	45
Threading Tools for the Oil & Gas Industries	33-34	External Holders - Acme	46
API Round	33	Internal Holders - Acme	47
V-0.040	34	Large Profile- Stub Acme	48
V-0.038R	34	External Holders - Stub Acme	49
V-0.050	34	Internal Holders - Stub Acme	50

A01-1

Product Identification

Thread Turning Inserts Ordering Codes

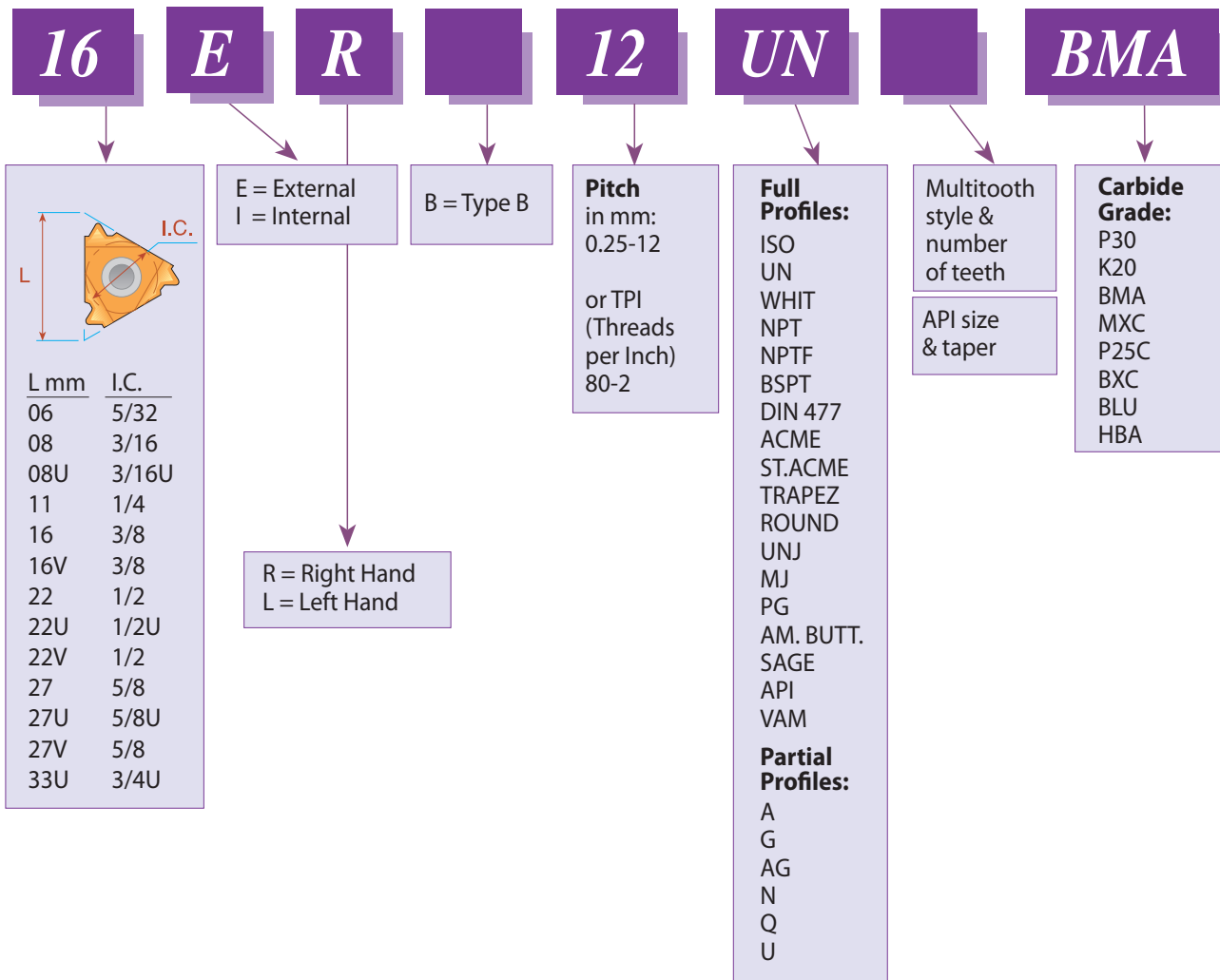

Thread Turning Inserts

Partial Profile 60°

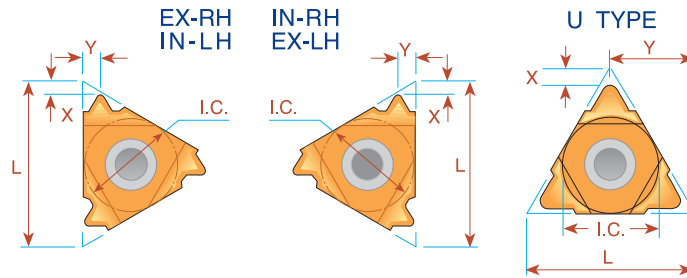
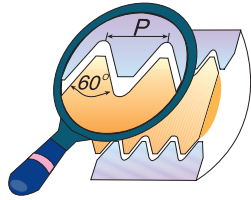

L mm	I.C.	Pitch Range		EXTERNAL		INTERNAL		X	Y
		mm	TPI	Ordering Code Right Hand	Ordering Code Left Hand	Ordering Code Right Hand	Ordering Code Left Hand		
6	5/32	0.5 - 1.25	48 - 20	ULTRA MINIATURE →		06 IR A60	06 IL A60	.02	.02
8	3/16	0.5 - 1.5	48 - 16	MINIATURE →		08 IR A60	08 IL A60	.02	.03
8U	3/16U	1.75 - 2.0	14 - 11	"U" MINIATURE →		08U IR/L U60		.03	.16
11	1/4	0.5 - 1.5	48 - 16	11 ER A60	11 EL A60	11 IR A60	11 IL A60	.03	.04
16	3/8	0.5 - 1.5	48 - 16	16 ER A60	16 EL A60	16 IR A60	16 IL A60	.03	.04
16	3/8	1.75 - 3.0	14 - 8	16 ER G60	16 EL G60	16 IR G60	16 IL G60	.05	.07
16	3/8	0.5 - 3.0	48 - 8	16 ER AG60	16 EL AG60	16 IR AG60	16 IL AG60	.05	.07
22	1/2	3.5 - 5.0	7 - 5	22 ER N60	22 EL N60	22 IR N60	22 IL N60	.07	.10
22U	1/2U	5.5 - 8.0	4.5 - 3.25	22U E/R/L U60				.02	.43
27	5/8	5.5 - 6.0	4.5 - 4	27 ER Q60	27 EL Q60	27 IR Q60	27 IL Q60	.08	.12
27U	5/8U	6.5 - 9.0	4 - 2.75	27U E/R/L U60				.04	.54

Order example: 16 ER G60 MXC

For small bore threading see page A06-12

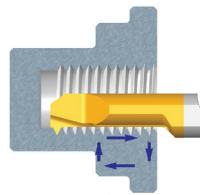

Type B

Ground profile with sintered chip-breaker



L mm	I.C.	Pitch Range		EXTERNAL		INTERNAL		X	Y
		mm	TPI	Ordering Code Right Hand	Ordering Code Right Hand	Ordering Code Right Hand	Ordering Code Right Hand		
16	3/8	0.5 - 1.5	48 - 16	16 ER B A60		16 IR B A60		.03	.04
16	3/8	1.75 - 3.0	14 - 8	16 ER B G60		16 IR B G60		.05	.07
16	3/8	0.5 - 3.0	48 - 8	16 ER B AG60		16 IR B AG60		.05	.07

Order example: 16 ER B G60 BMA

For carbide grade and cutting speed see page A04-2 and 3

Partial Profile 60° Vertical

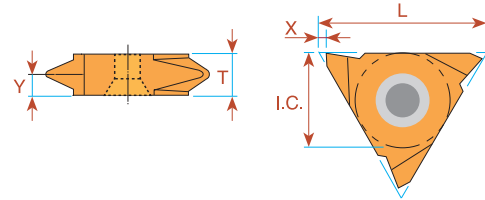

L mm	I.C.	Pitch Range		EXTERNAL Ordering Code		INTERNAL Ordering Code		X	Y	T
		mm	TPI	Right Hand	Left Hand	Right Hand	Left Hand			
16	3/8	0.5 - 1.5	48 - 16	16V ER A60	16V EL A60			.04	.04	.14
16	3/8	1.75 - 3.0	14 - 8	16V ER G60	16V EL G60			.04	.07	.14
16	3/8	0.5 - 3.0	48 - 8	16V ER AG60	16V EL AG60			.04	.07	.14
22	1/2	1.75 - 3.0	14 - 8	22V ER G60	22V EL G60			.05	.07	.16
22	1/2	0.5 - 5.0	7 - 5	22V ER N60	22V EL N60			.05	.10	.19
27	5/8	6.0 - 10.0	4 - 2.5	27V ER V60	27V EL V60	27V IR V60	27V IL V60	.07	.20	.41

Order example: 16V ER G60 BMA

For carbide grade and cutting speed see page A04-2 and 3

Thread Turning Inserts

Partial Profile 55°

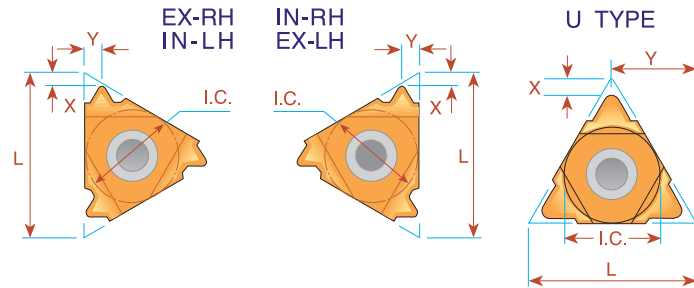
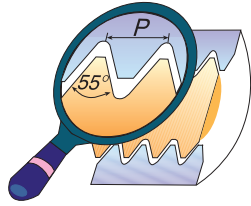

L mm	I.C.	Pitch Range		EXTERNAL		INTERNAL		X	Y
		mm	TPI	Ordering Code	Ordering Code	Ordering Code	Ordering Code		
				Right Hand	Left Hand	Right Hand	Left Hand		
6	5/32	0.5 - 1.25	48 - 20	<i>ULTRA MINIATURE</i> →		06 IR A55	06 IL A55	.02	.02
8	3/16	0.5 - 1.5	48 - 16	<i>MINIATURE</i> →		08 IR A55	08 IL A55	.02	.03
8U	3/16U	1.75 - 2.0	14 - 11	<i>"U" MINIATURE</i> →		08U IR/L U55		.03	.16
11	1/4	0.5 - 1.5	48 - 16	11 ER A55	11 EL A55	11 IR A55	11 IL A55	.03	.04
16	3/8	0.5 - 1.5	48 - 16	16 ER A55	16 EL A55	16 IR A55	16 IL A55	.03	.04
16	3/8	1.75 - 3.0	14 - 8	16 ER G55	16 EL G55	16 IR G55	16 IL G55	.05	.07
16	3/8	0.5 - 3.0	48 - 8	16 ER AG55	16 EL AG55	16 IR AG55	16 IL AG55	.05	.07
22	1/2	3.5 - 5.0	7 - 5	22 ER N55	22 EL N55	22 IR N55	22 IL N55	.07	.10
22U	1/2U	5.5 - 8.0	4.5 - 3.25	22U E/R/L U55				.04	.43
27	5/8	5.5 - 6.0	4.5 - 4	27 ER Q55	27 EL Q55	27 IR Q55	27 IL Q55	.08	.11
27U	5/8U	6.5 - 9.0	4 - 2.75	27U E/R/L U55				.05	.54

Order example: 16 ER G55 MXC
For small bore threading see page A06-12

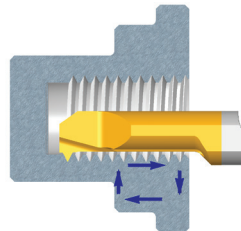

Type B

Ground Profile with Sintered Chip-breaker



L mm	I.C.	Pitch Range		EXTERNAL	INTERNAL	X	Y
		mm	TPI	Ordering Code	Ordering Code		
				Right Hand	Right Hand		
16	3/8	1.75 - 3.0	14 - 8	16 ER B G55	16 IR B G55	.05	.07
16	3/8	0.5 - 3.0	48 - 8	16 ER B AG55	16 IR B AG55	.05	.07

Order example: 16 ER B G55 BMA
For carbide grade and cutting speed see page A04-2 and 3

Partial Profile 55° Vertical

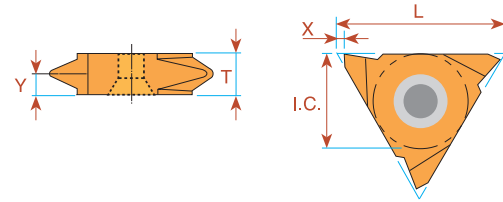

L mm	I.C.	Pitch Range		EXTERNAL Ordering Code		INTERNAL Ordering Code		X	Y	T
		mm	TPI	Right Hand	Left Hand	Right Hand	Left Hand			
16	3/8	0.5 - 1.5	48 - 16	16V ER A55	16V EL A55			.04	.04	.14
16	3/8	1.75 - 3.0	14 - 8	16V ER G55	16V EL G55			.04	.07	.14
16	3/8	0.5 - 3.0	48 - 8	16V ER AG55	16V EL AG55			.04	.07	.14
22	1/2	3.5 - 5.0	7 - 5	22V ER N55	22V EL N55			.05	.10	.19
27	5/8	6.0 - 10.0	4 - 2.5	27V ER V55	27V EL V55	27V IR V55	27V IL V55	.07	.20	.41

Order example: 22V ER N55 BMA

For carbide grade and cutting speed see page A04-2 and 3

Thread Turning Inserts

ISO - metric

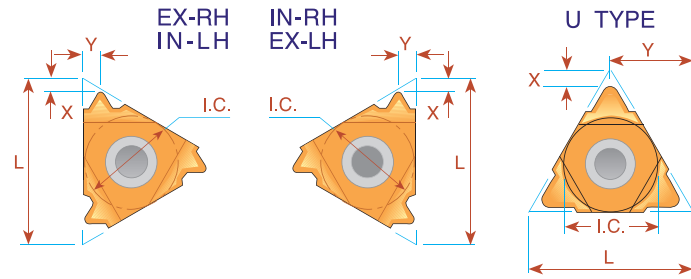
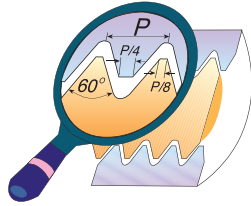

Pitch mm	L mm	I.C.	EXTERNAL		X	Y	INTERNAL		X	Y
			Right Hand	Left Hand			Right Hand	Left Hand		
0.25	6	5/32					06 IR 0.25 ISO	06 IL 0.25 ISO	.03	.01
0.5	6	5/32					06 IR 0.5 ISO	06 IL 0.5 ISO	.04	.02
0.75	6	5/32	<i>ULTRA MINIATURE</i> →				06 IR 0.75 ISO	06 IL 0.75 ISO	.03	.02
1.0	6	5/32					06 IR 1.0 ISO	06 IL 1.0 ISO	.03	.02
1.25	6	5/32					06 IR 1.25 ISO	06 IL 1.25 ISO	.02	.02
0.25	8	3/16					08 IR 0.25 ISO	08 IL 0.25 ISO	.03	.01
0.5	8	3/16					08 IR 0.5 ISO	08 IL 0.5 ISO	.02	.02
0.75	8	3/16	<i>MINIATURE</i> →				08 IR 0.75 ISO	08 IL 0.75 ISO	.02	.02
1.0	8	3/16					08 IR 1.0 ISO	08 IL 1.0 ISO	.02	.02
1.25	8	3/16					08 IR 1.25 ISO	08 IL 1.25 ISO	.02	.03
1.5	8	3/16					08 IR 1.5 ISO	08 IL 1.5 ISO	.02	.03
1.75	8	3/16					08 IR 1.75 ISO	08 IL 1.75 ISO	.02	.03
2.0	8U	3/16U	<i>"U" MINIATURE</i> →				08U IR/L 2.0 ISO		.04	.16
0.25	11	1/4	11 ER 0.25 ISO	11 EL 0.25 ISO	.03	.01				
0.3	11	1/4	11 ER 0.3 ISO	11 EL 0.3 ISO	.02	.01				
0.35	11	1/4	11 ER 0.35 ISO	11 EL 0.35 ISO	.03	.02	11 IR 0.35 ISO	11 IL 0.35 ISO	.03	.01
0.4	11	1/4	11 ER 0.4 ISO	11 EL 0.4 ISO	.03	.02	11 IR 0.4 ISO	11 IL 0.4 ISO	.03	.02
0.45	11	1/4	11 ER 0.45 ISO	11 EL 0.45 ISO	.03	.02	11 IR 0.45 ISO	11 IL 0.45 ISO	.03	.02
0.5	11	1/4	11 ER 0.5 ISO	11 EL 0.5 ISO	.02	.02	11 IR 0.5 ISO	11 IL 0.5 ISO	.02	.02
0.6	11	1/4	11 ER 0.6 ISO	11 EL 0.6 ISO	.02	.02	11 IR 0.6 ISO	11 IL 0.6 ISO	.02	.02
0.7	11	1/4	11 ER 0.7 ISO	11 EL 0.7 ISO	.02	.02	11 IR 0.7 ISO	11 IL 0.7 ISO	.02	.02
0.75	11	1/4	11 ER 0.75 ISO	11 EL 0.75 ISO	.02	.02	11 IR 0.75 ISO	11 IL 0.75 ISO	.02	.02
0.8	11	1/4	11 ER 0.8 ISO	11 EL 0.8 ISO	.02	.02	11 IR 0.8 ISO	11 IL 0.8 ISO	.02	.02
1.0	11	1/4	11 ER 1.0 ISO	11 EL 1.0 ISO	.03	.03	11 IR 1.0 ISO	11 IL 1.0 ISO	.02	.03
1.25	11	1/4	11 ER 1.25 ISO	11 EL 1.25 ISO	.03	.04	11 IR 1.25 ISO	11 IL 1.25 ISO	.03	.03
1.5	11	1/4	11 ER 1.5 ISO	11 EL 1.5 ISO	.03	.04	11 IR 1.5 ISO	11 IL 1.5 ISO	.03	.04
1.75	11	1/4	11 ER 1.75 ISO	11 EL 1.75 ISO	.03	.04	11 IR 1.75 ISO	11 IL 1.75 ISO	.03	.04
2.0	11	1/4	11 ER 2.0 ISO	11 EL 2.0 ISO	.03	.04	11 IR 2.0 ISO	11 IL 2.0 ISO	.03	.04
2.5	11	1/4					11 IR 2.5 ISO	11 IL 2.5 ISO	.03	.05
0.25	16	3/8	16 ER 0.25 ISO	16 EL 0.25 ISO	.03	.01				
0.3	16	3/8	16 ER 0.3 ISO	16 EL 0.3 ISO	.02	.01				
0.35	16	3/8	16 ER 0.35 ISO	16 EL 0.35 ISO	.03	.02	16 IR 0.35 ISO	16 IL 0.35 ISO	.03	.01
0.4	16	3/8	16 ER 0.4 ISO	16 EL 0.4 ISO	.03	.02	16 IR 0.4 ISO	16 IL 0.4 ISO	.03	.02
0.45	16	3/8	16 ER 0.45 ISO	16 EL 0.45 ISO	.03	.02	16 IR 0.45 ISO	16 IL 0.45 ISO	.03	.02
0.5	16	3/8	16 ER 0.5 ISO	16 EL 0.5 ISO	.02	.02	16 IR 0.5 ISO	16 IL 0.5 ISO	.02	.02
0.6	16	3/8	16 ER 0.6 ISO	16 EL 0.6 ISO	.02	.02	16 IR 0.6 ISO	16 IL 0.6 ISO	.02	.02
0.7	16	3/8	16 ER 0.7 ISO	16 EL 0.7 ISO	.02	.02	16 IR 0.7 ISO	16 IL 0.7 ISO	.02	.02
0.75	16	3/8	16 ER 0.75 ISO	16 EL 0.75 ISO	.02	.02	16 IR 0.75 ISO	16 IL 0.75 ISO	.02	.02
0.8	16	3/8	16 ER 0.8 ISO	16 EL 0.8 ISO	.02	.02	16 IR 0.8 ISO	16 IL 0.8 ISO	.02	.02
1.0	16	3/8	16 ER 1.0 ISO	16 EL 1.0 ISO	.03	.03	16 IR 1.0 ISO	16 IL 1.0 ISO	.02	.03
1.25	16	3/8	16 ER 1.25 ISO	16 EL 1.25 ISO	.03	.04	16 IR 1.25 ISO	16 IL 1.25 ISO	.03	.03
1.5	16	3/8	16 ER 1.5 ISO	16 EL 1.5 ISO	.03	.04	16 IR 1.5 ISO	16 IL 1.5 ISO	.03	.04
1.75	16	3/8	16 ER 1.75 ISO	16 EL 1.75 ISO	.04	.05	16 IR 1.75 ISO	16 IL 1.75 ISO	.04	.05
2.0	16	3/8	16 ER 2.0 ISO	16 EL 2.0 ISO	.04	.05	16 IR 2.0 ISO	16 IL 2.0 ISO	.04	.05
2.5	16	3/8	16 ER 2.5 ISO	16 EL 2.5 ISO	.04	.06	16 IR 2.5 ISO	16 IL 2.5 ISO	.04	.06
3.0	16	3/8	16 ER 3.0 ISO	16 EL 3.0 ISO	.05	.06	16 IR 3.0 ISO	16 IL 3.0 ISO	.04	.06
3.5	16	3/8	16 ER 3.5 ISO	16 EL 3.5 ISO	.05	.06	16 IR 3.5 ISO	16 IL 3.5 ISO	.05	.07

ISO - metric

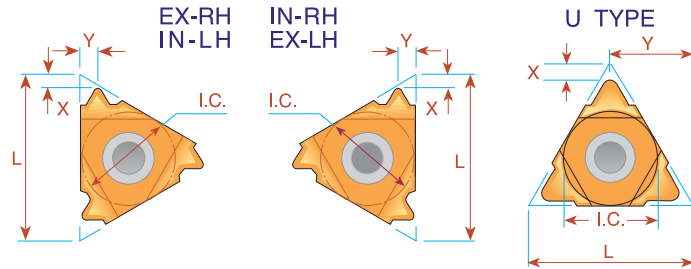
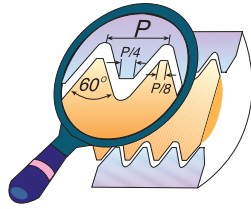

Pitch mm	L mm	I.C.	EXTERNAL		X	Y	INTERNAL		X	Y
			Ordering Code Right Hand	Ordering Code Left Hand			Ordering Code Right Hand	Ordering Code Left Hand		
3.5	22	1/2	22 ER 3.5 ISO	22 EL 3.5 ISO	.06	.09	22 IR 3.5 ISO	22 IL 3.5 ISO	.06	.09
4.0	22	1/2	22 ER 4.0 ISO	22 EL 4.0 ISO	.06	.09	22 IR 4.0 ISO	22 IL 4.0 ISO	.06	.09
4.5	22	1/2	22 ER 4.5 ISO	22 EL 4.5 ISO	.07	.09	22 IR 4.5 ISO	22 IL 4.5 ISO	.06	.09
5.0	22	1/2	22 ER 5.0 ISO	22 EL 5.0 ISO	.07	.10	22 IR 5.0 ISO	22 IL 5.0 ISO	.06	.09
5.5	22	1/2	22 ER 5.5 ISO	22 EL 5.5 ISO	.07	.10	22 IR 5.5 ISO	22 IL 5.5 ISO	.06	.09
6.0	22	1/2	*22 ER 6.0 ISO	*22 EL 6.0 ISO	.07	.11	22 IR 6.0 ISO	22 IL 6.0 ISO	.06	.09
5.5	22U	1/2U	22U ER/L 5.5 ISO		.09	.43	22U IR/L 5.5 ISO		.09	.43
6.0	22U	1/2U	22U ER/L 6.0 ISO		.10	.43	22U IR/L 6.0 ISO		.08	.43
5.5	27	5/8	27 ER 5.5 ISO	27 EL 5.5 ISO	.07	.11	27 IR 5.5 ISO	27 IL 5.5 ISO	.06	.09
6.0	27	5/8	27 ER 6.0 ISO	27 EL 6.0 ISO	.08	.11	27 IR 6.0 ISO	27 IL 6.0 ISO	.07	.10
8.0	27U	5/8U	27U ER/L 8.0 ISO		.09	.54	27U IR/L 8.0 ISO		.09	.54
12.0	33U	3/4U	33U ER/L 12.0 ISO		.10	.65	33U IR/L 12.0 ISO		.14	.67

* Special holder required

Order example: 22 IR 3.5 ISO BMA

For small bore threading see page A06-13

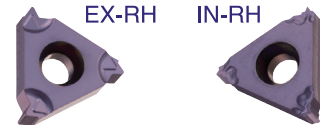
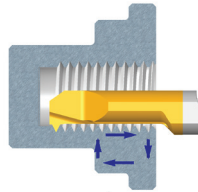

Type B

Ground Profile with Sintered Chip-breaker

Pitch mm	L mm	I.C.	EXTERNAL		X	Y	INTERNAL		X	Y
			Ordering Code Right Hand	Ordering Code Left Hand			Ordering Code Right Hand	Ordering Code Left Hand		
0.5	11	1/4					11 IR B 0.5 ISO		.02	.02
0.75	11	1/4					11 IR B 0.75 ISO		.02	.02
0.8	11	1/4					11 IR B 0.8 ISO		.02	.02
1.0	11	1/4					11 IR B 1.0 ISO		.02	.02
1.25	11	1/4					11 IR B 1.25 ISO		.03	.04
1.5	11	1/4					11 IR B 1.5 ISO		.03	.04
1.75	11	1/4					11 IR B 1.75 ISO		.03	.04
2.0	11	1/4					11 IR B 2.0 ISO		.03	.04
0.8	16	3/8	16 ER B 0.8 ISO		.02	.02				
1.0	16	3/8	16 ER B 1.0 ISO		.03	.03			.02	.03
1.25	16	3/8	16 ER B 1.25 ISO		.03	.04			.03	.03
1.5	16	3/8	16 ER B 1.5 ISO		.03	.04			.03	.04
1.75	16	3/8	16 ER B 1.75 ISO		.04	.05			.04	.05
2.0	16	3/8	16 ER B 2.0 ISO		.04	.05			.04	.05
2.5	16	3/8	16 ER B 2.5 ISO		.04	.06			.04	.06
3.0	16	3/8	16 ER B 3.0 ISO		.05	.06			.04	.06

Order example: 16 IR B 1.5 ISO BMA

For carbide grade and cutting speed see page A04-2 and 3

Thread Turning Inserts

ISO - metric Vertical

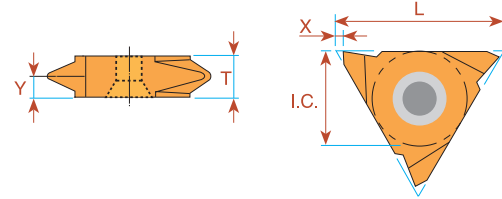

Pitch mm	L mm	I.C.	EXTERNAL		INTERNAL		X	Y	T
			Right Hand	Left Hand	Right Hand	Left Hand			
0.5	16	3/8	16V ER 0.5 ISO	16V EL 0.5 ISO			.04	.02	.14
0.75	16	3/8	16V ER 0.75 ISO	16V EL 0.75 ISO			.04	.02	.14
0.8	16	3/8	16V ER 0.8 ISO	16V EL 0.8 ISO			.04	.02	.14
1.0	16	3/8	16V ER 1.0 ISO	16V EL 1.0 ISO			.04	.03	.14
1.25	16	3/8	16V ER 1.25 ISO	16V EL 1.25 ISO			.04	.04	.14
1.5	16	3/8	16V ER 1.5 ISO	16V EL 1.5 ISO			.04	.04	.14
1.75	16	3/8	16V ER 1.75 ISO	16V EL 1.75 ISO			.04	.05	.14
2.0	16	3/8	16V ER 2.0 ISO	16V EL 2.0 ISO			.04	.05	.14
2.5	16	3/8	16V ER 2.5 ISO	16V EL 2.5 ISO			.04	.06	.14
3.0	16	3/8	16V ER 3.0 ISO	16V EL 3.0 ISO			.04	.07	.14
* 8.0	27	5/8	27V ER 8.0 ISO	27V EL 8.0 ISO	27V IR 8.0 ISO	27 IL 8.0 ISO	.07	.20	.41
** 10.0	27	5/8	27V ER 10.0 ISO	27V EL 10.0 ISO	27V IR 10.0 ISO	27 IL 10.0 ISO	.07	.20	.41

Order example: 16V ER 1.5 ISO BMA

- * Minimum bore: 2.36
- ** Minimum bore: 2.83

Multitooth

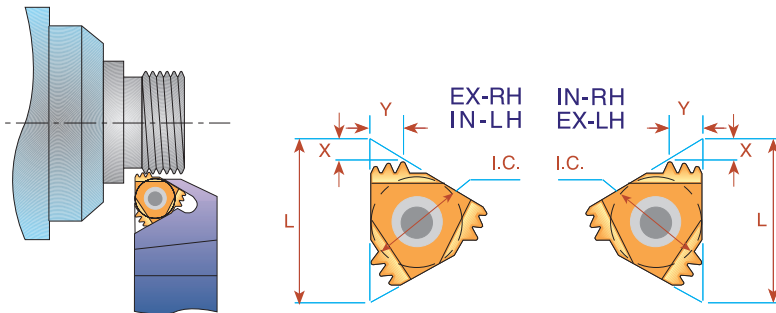

Pitch mm	L mm	I.C.	Number of Teeth	EXTERNAL	Anvil	INTERNAL	Anvil	X	Y
				Ordering Code		Ordering Code			
1.0	16	3/8	3	16 ER 1.0 ISO 3M	AE16M	16 IR 1.0 ISO 3M	AI16M	.07	.10
1.5	16	3/8	2	16 ER 1.5 ISO 2M	AE16M	16 IR 1.5 ISO 2M	AI16M	.06	.09
2.0	16	3/8	2	16 ER 2.0 ISO 2M	AE16M	16 IR 2.0 ISO 2M	AI16M	.06	.09
1.5	22	1/2	3	22 ER 1.5 ISO 3M	AE22M	22 IR 1.5 ISO 3M	AI22M	.09	.15
2.0	22	1/2	2	22 ER 2.0 ISO 2M	AE22M	22 IR 2.0 ISO 2M	AI22M	.08	.12
2.0	22	1/2	3	22 ER 2.0 ISO 3M	AE22M	22 IR 2.0 ISO 3M	AI22M	.12	.20
2.5	22	1/2	2	22 ER 2.5 ISO 2M	AE22M	22 IR 2.5 ISO 2M	AI22M	.09	.15
2.5	22	1/2	3	22 ER 2.5 ISO 3M	AE22M	22 IR 2.5 ISO 3M	AI22M	.15	.24
3.0	27	5/8	2	27 ER 3.0 ISO 2M	AE27M	27 IR 3.0 ISO 2M	AI27M	.11	.18

Order example: 22 IR 2.0 ISO 2M BMA

For recommended number of passes see page A04-4

For carbide grade and cutting speed see page A04-2 and 3

Thread Turning Inserts

UN - Unified UNC, UNF, UNEF, UNS

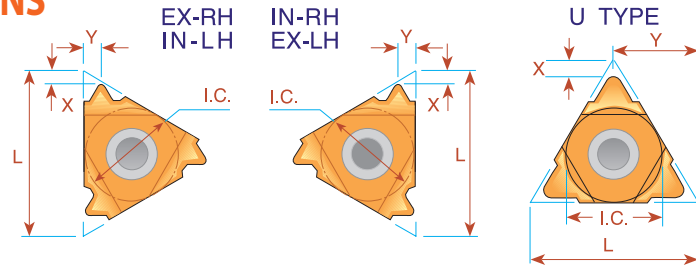
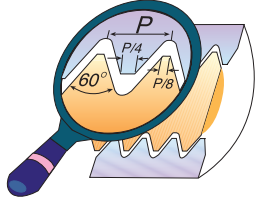

Pitch TPI	L mm	I.C.	EXTERNAL			INTERNAL				
			Ordering Code Right Hand	Ordering Code Left Hand	X	Y	Ordering Code Right Hand	Ordering Code Left Hand	X	Y
32	6	5/32	<i>ULTRA MINIATURE</i> →				06 IR 32 UN	06 IL 32 UN	.03	.02
28	6	5/32					06 IR 28 UN	06 IL 28 UN	.03	.02
24	6	5/32					06 IR 24 UN	06 IL 24 UN	.03	.02
20	6	5/32					06 IR 20 UN	06 IL 20 UN	.02	.02
18	6	5/32					06 IR 18 UN	06 IL 18 UN	.02	.03
32	8	3/16		<i>MINIATURE</i> →				08 IR 32 UN	08 IL 32 UN	.02
28	8	3/16					08 IR 28 UN	08 IL 28 UN	.02	.02
24	8	3/16					08 IR 24 UN	08 IL 24 UN	.02	.02
20	8	3/16					08 IR 20 UN	08 IL 20 UN	.02	.03
18	8	3/16					08 IR 18 UN	08 IL 18 UN	.02	.03
16	8	3/16					08 IR 16 UN	08 IL 16 UN	.02	.03
14	8	3/16					08 IR 14 UN	08 IL 14 UN	.02	.03
13	8	3/16					**08 IR 13 UN		.03	.04
13	8U	3/16U	<i>"U" MINIATURE</i> →				08U IR/L 13 UN		.04	.16
12	8U	3/16U					08U IR/L 12 UN		.04	.16
11	8U	3/16U					08U IR/L 11 UN		.04	.16
80	11	1/4	11 ER 80 UN	11 EL 80 UN	.03	.02	11 IR 80 UN	11 IL 80 UN	.03	.02
72	11	1/4	11 ER 72 UN	11 EL 72 UN	.03	.02	11 IR 72 UN	11 IL 72 UN	.03	.01
64	11	1/4	11 ER 64 UN	11 EL 64 UN	.03	.02	11 IR 64 UN	11 IL 64 UN	.03	.02
56	11	1/4	11 ER 56 UN	11 EL 56 UN	.03	.02	11 IR 56 UN	11 IL 56 UN	.03	.02
48	11	1/4	11 ER 48 UN	11 EL 48 UN	.02	.02	11 IR 48 UN	11 IL 48 UN	.02	.02
44	11	1/4	11 ER 44 UN	11 EL 44 UN	.02	.02	11 IR 44 UN	11 IL 44 UN	.02	.02
40	11	1/4	11 ER 40 UN	11 EL 40 UN	.02	.02	11 IR 40 UN	11 IL 40 UN	.02	.02
36	11	1/4	11 ER 36 UN	11 EL 36 UN	.02	.02	11 IR 36 UN	11 IL 36 UN	.02	.02
32	11	1/4	11 ER 32 UN	11 EL 32 UN	.02	.02	11 IR 32 UN	11 IL 32 UN	.02	.02
28	11	1/4	11 ER 28 UN	11 EL 28 UN	.02	.03	11 IR 28 UN	11 IL 28 UN	.02	.03
27	11	1/4	11 ER 27 UN	11 EL 27 UN	.03	.03	11 IR 27 UN	11 IL 27 UN	.03	.03
24	11	1/4	11 ER 24 UN	11 EL 24 UN	.03	.03	11 IR 24 UN	11 IL 24 UN	.03	.03
20	11	1/4	11 ER 20 UN	11 EL 20 UN	.03	.04	11 IR 20 UN	11 IL 20 UN	.03	.04
18	11	1/4	11 ER 18 UN	11 EL 18 UN	.03	.04	11 IR 18 UN	11 IL 18 UN	.03	.04
16	11	1/4	11 ER 16 UN	11 EL 16 UN	.04	.04	11 IR 16 UN	11 IL 16 UN	.04	.04
14	11	1/4	11 ER 14 UN	11 EL 14 UN	.04	.04	11 IR 14 UN	11 IL 14 UN	.04	.04
13	11	1/4					11 IR 13 UN	11 IL 13 UN	.03	.04
12	11	1/4					11 IR 12 UN	11 IL 12 UN	.04	.04
11	11	1/4					11 IR 11 UN	11 IL 11 UN	.03	.04
80	16	3/8	16 ER 80 UN	16 EL 80 UN	.03	.02	16 IR 80 UN	16 IL 80 UN	.03	.02
72	16	3/8	16 ER 72 UN	16 EL 72 UN	.03	.02	16 IR 72 UN	16 IL 72 UN	.03	.01
64	16	3/8	16 ER 64 UN	16 EL 64 UN	.03	.02	16 IR 64 UN	16 IL 64 UN	.03	.02
56	16	3/8	16 ER 56 UN	16 EL 56 UN	.03	.02	16 IR 56 UN	16 IL 56 UN	.03	.02
48	16	3/8	16 ER 48 UN	16 EL 48 UN	.02	.02	16 IR 48 UN	16 IL 48 UN	.02	.02
44	16	3/8	16 ER 44 UN	16 EL 44 UN	.02	.02	16 IR 44 UN	16 IL 44 UN	.02	.02
40	16	3/8	16 ER 40 UN	16 EL 40 UN	.02	.02	16 IR 40 UN	16 IL 40 UN	.02	.02
36	16	3/8	16 ER 36 UN	16 EL 36 UN	.02	.02	16 IR 36 UN	16 IL 36 UN	.02	.02

** To be used with Holder SIR 0009 K08 on page A02-10

A01-10

Thread Turning Inserts

UN - Unified **UNC, UNF, UNEF, UNS**

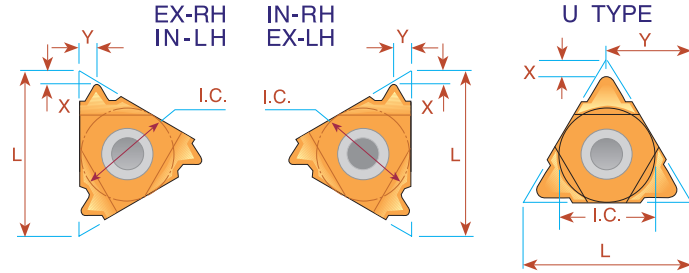
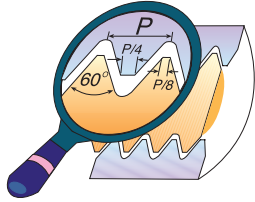

Pitch TPI	L mm	I.C.	EXTERNAL		X	Y	INTERNAL		X	Y
			Ordering Code				Ordering Code			
			Right Hand	Left Hand			Right Hand	Left Hand		
32	16	3/8	16 ER 32 UN	16 EL 32 UN	.02	.02	16 IR 32 UN	16 IL 32 UN	.02	.02
28	16	3/8	16 ER 28 UN	16 EL 28 UN	.02	.03	16 IR 28 UN	16 IL 28 UN	.02	.03
27	16	3/8	16 ER 27 UN	16 EL 27 UN	.03	.03	16 IR 27 UN	16 IL 27 UN	.03	.03
24	16	3/8	16 ER 24 UN	16 EL 24 UN	.03	.03	16 IR 24 UN	16 IL 24 UN	.03	.03
20	16	3/8	16 ER 20 UN	16 EL 20 UN	.03	.04	16 IR 20 UN	16 IL 20 UN	.03	.04
18	16	3/8	16 ER 18 UN	16 EL 18 UN	.03	.04	16 IR 18 UN	16 IL 18 UN	.03	.04
16	16	3/8	16 ER 16 UN	16 EL 16 UN	.04	.04	16 IR 16 UN	16 IL 16 UN	.04	.04
14	16	3/8	16 ER 14 UN	16 EL 14 UN	.04	.05	16 IR 14 UN	16 IL 14 UN	.04	.05
13	16	3/8	16 ER 13 UN	16 EL 13 UN	.04	.05	16 IR 13 UN	16 IL 13 UN	.04	.05
12	16	3/8	16 ER 12 UN	16 EL 12 UN	.04	.06	16 IR 12 UN	16 IL 12 UN	.04	.06
11.5	16	3/8	16 ER 11.5 UN	16 EL 11.5 UN	.04	.06	16 IR 11.5 UN	16 IL 11.5 UN	.04	.06
11	16	3/8	16 ER 11 UN	16 EL 11 UN	.04	.06	16 IR 11 UN	16 IL 11 UN	.04	.06
10	16	3/8	16 ER 10 UN	16 EL 10 UN	.04	.06	16 IR 10 UN	16 IL 10 UN	.04	.06
9	16	3/8	16 ER 9 UN	16 EL 9 UN	.05	.07	16 IR 9 UN	16 IL 9 UN	.05	.07
8	16	3/8	16 ER 8 UN	16 EL 8 UN	.05	.06	16 IR 8 UN	16 IL 8 UN	.04	.06
7	22	1/2	22 ER 7 UN	22 EL 7 UN	.06	.09	22 IR 7 UN	22 IL 7 UN	.06	.09
6	22	1/2	22 ER 6 UN	22 EL 6 UN	.06	.09	22 IR 6 UN	22 IL 6 UN	.06	.09
5	22	1/2	22 ER 5 UN	22 EL 5 UN	.07	.10	22 IR 5 UN	22 IL 5 UN	.06	.09
4.5	22U	1/2U	22U ER/L 4.5 UN		.08	.43	22U IR/L 4.5 UN		.09	.43
4	22U	1/2U	22U ER/L 4 UN		.08	.43	22U IR/L 4 UN		.09	.43
4.5	27	5/8	27 ER 4.5 UN	27 EL 4.5 UN	.07	.11	27 IR 4.5 UN	27 IL 4.5 UN	.07	.09
4	27	5/8	27 ER 4 UN	27 EL 4 UN	.08	.12	27 IR 4 UN	27 IL 4 UN	.07	.11
3	27U	5/8U	27U ER/L 3 UN		.10	.54	27U IR/L 3 UN		.11	.54
2	33U	3/4U	33U ER/L 2 UN		.11	.65	33U IR/L 2 UN		.14	.67

Order example: 22ER 7 UN BMA
 For small bore threading see page A06-13

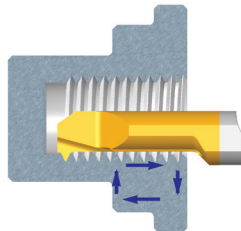

For carbide grade and cutting speed see page A04-2 and 3

UN - Unified Vertical

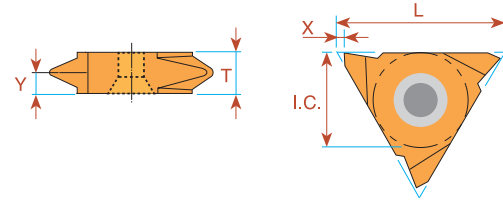

Pitch TPI	L mm	I.C.	EXTERNAL		INTERNAL		X	Y	T
			Ordering Code Right Hand	Ordering Code Left Hand	Ordering Code Right Hand	Ordering Code Left Hand			
32	16	3/8	16V ER 32 UN	16V EL 32 UN			.04	.02	.14
28	16	3/8	16V ER 28 UN	16V EL 28 UN			.04	.03	.14
24	16	3/8	16V ER 24 UN	16V EL 24 UN			.04	.03	.14
20	16	3/8	16V ER 20 UN	16V EL 20 UN			.04	.03	.14
18	16	3/8	16V ER 18 UN	16V EL 18 UN			.04	.04	.14
16	16	3/8	16V ER 16 UN	16V EL 16 UN			.04	.04	.14
14	16	3/8	16V ER 14 UN	16V EL 14 UN			.04	.05	.14
12	16	3/8	16V ER 12 UN	16V EL 12 UN			.04	.05	.14
10	16	3/8	16V ER 10 UN	16V EL 10 UN			.04	.06	.14
8	16	3/8	16V ER 8 UN	16V EL 8 UN			.04	.06	.14
7	22	1/2	22V ER 7 UN	22V EL 7 UN			.05	.09	.19
* 3	27	5/8	27V ER 3 UN	27V EL 3 UN	27V IR 3 UN	27 IL 3 UN	.07	.20	.41

Order example: 22V ER 7UN MXC

* Minimum bore: Ø2.56

UN - Unified Type B **UNC, UNF, UNEF, UNS**

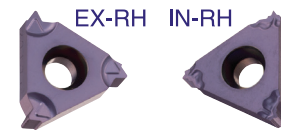

Ground Profile with Sintered Chip-breaker

Pitch TPI	L mm	I.C.	EXTERNAL		X	Y	INTERNAL		X	Y
			Ordering Code Right Hand	Ordering Code Right Hand			Ordering Code Right Hand	Ordering Code Right Hand		
32	11	1/4					11 IR B 32 UN		.02	.02
28	11	1/4					11 IR B 28 UN		.02	.02
24	11	1/4					11 IR B 24 UN		.02	.02
20	11	1/4					11 IR B 20 UN		.03	.04
18	11	1/4					11 IR B 18 UN		.03	.04
16	11	1/4					11 IR B 16 UN		.03	.04
14	11	1/4					11 IR B 14 UN		.03	.04
12	11	1/4					11 IR B 12 UN		.03	.04
24	16	3/8	16 ER B 24 UN		.03	.03	16 IR B 24 UN		.03	.03
20	16	3/8	16 ER B 20 UN		.03	.04	16 IR B 20 UN		.03	.03
18	16	3/8	16 ER B 18 UN		.03	.04	16 IR B 18 UN		.03	.03
16	16	3/8	16 ER B 16 UN		.04	.04	16 IR B 16 UN		.04	.04
14	16	3/8	16 ER B 14 UN		.04	.05	16 IR B 14 UN		.04	.05
13	16	3/8	16 ER B 13 UN		.04	.05				
12	16	3/8	16 ER B 12 UN		.04	.06	16 IR B 12 UN		.04	.06
11	16	3/8	16 ER B 11 UN		.04	.06				
10	16	3/8	16 ER B 10 UN		.04	.06	16 IR B 10 UN		.04	.06
9	16	3/8	16 ER B 9 UN		.05	.07				
8	16	3/8	16 ER B 8 UN		.05	.06	16 IR B 8 UN		.04	.06

Order example: 16 IR B 12 UN BMA

A01-12

Thread Turning Inserts

Multitooth

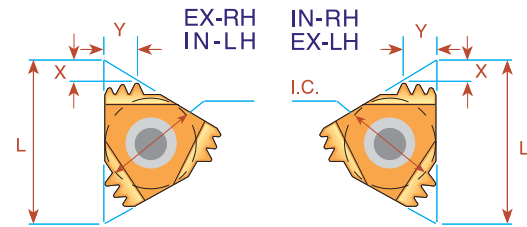
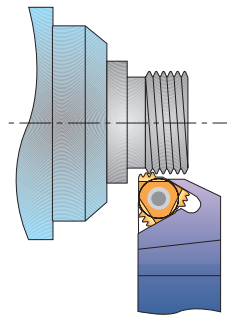

Pitch TPI	L mm	I.C.	Number of Teeth	EXTERNAL	Anvil	INTERNAL	Anvil	X	Y
				Ordering Code		Ordering Code			
24	16	3/8	2	16 ER 24 UN 2M	AE16M	16 IR 24 UN 2M	AI16M	.04	.07
20	16	3/8	2	16 ER 20 UN 2M	AE16M	16 IR 20 UN 2M	AI16M	.06	.08
18	16	3/8	2	16 ER 18 UN 2M	AE16M	16 IR 18 UN 2M	AI16M	.06	.09
16	16	3/8	2	16 ER 16 UN 2M	AE16M	16 IR 16 UN 2M	AI16M	.06	.09
14	16	3/8	2	16 ER 14 UN 2M	AE16M	16 IR 14 UN 2M	AI16M	.07	.11
12	16	3/8	2	16 ER 12 UN 2M	AE16M	16 IR 12 UN 2M	AI16M	.08	.12
16	22	1/2	3	22 ER 16 UN 3M	AE22M	22 IR 16 UN 3M	AI22M	.10	.16
13	22	1/2	3	22 ER 13 UN 3M	AE22M	-	AI22M	.12	.19
12	22	1/2	2	22 ER 12 UN 2M	AE22M	22 IR 12 UN 2M	AI22M	.09	.13
12	22	1/2	3	22 ER 12 UN 3M	AE22M	22 IR 12 UN 3M	AI22M	.13	.21
8	27	5/8	2	27 ER 8 UN 2M	AE27M	27 IR 8 UN 2M	AI27M	.12	.19

Order example: 22 IR 16 UN 3M BMA

For recommended number of passes see page A04-4

For carbide grade and cutting speed see page A04-2 and 3

Whitworth - 55° BSW, BSF, BSP, BSB

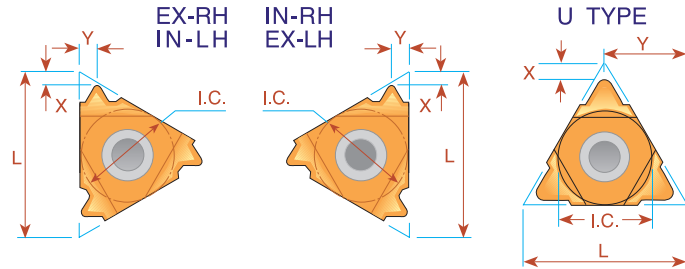
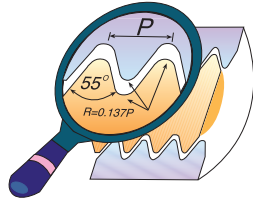

Pitch TPI	L mm	I.C.	EXTERNAL		INTERNAL		X	Y
			Ordering Code Right Hand	Ordering Code Left Hand	Ordering Code Right Hand	Ordering Code Left Hand		
26	6	5/32	<i>ULTRA MINIATURE</i> →		06 IR 26 W	06 IL 26 W	.03	.02
22	6	5/32			06 IR 22 W	06 IL 22 W	.02	.02
20	6	5/32			06 IR 20 W	06 IL 20 W	.02	.03
18	6	5/32			06 IR 18 W	06 IL 18 W	.02	.03
28	8	3/16	<i>MINIATURE</i> →		08 IR 28 W	08 IL 28 W	.02	.02
24	8	3/16			08 IR 24 W	08 IL 24 W	.02	.02
20	8	3/16			08 IR 20 W	08 IL 20 W	.02	.03
19	8	3/16			08 IR 19 W	08 IL 19 W	.02	.03
18	8	3/16			08 IR 18 W	08 IL 18 W	.02	.03
16	8	3/16			08 IR 16 W	08 IL 16 W	.02	.03
14	8U	3/16U	<i>"U" MINIATURE</i> →		08U IR/L 14 W		.04	.16
12	8U	3/16U			08U IR/L 12 W		.04	.16
11	8U	3/16U			08U IR/L 11 W		.04	.16
72	11	1/4	11 ER 72 W	11 EL 72 W	11 IR 72 W	11 IL 72 W	.03	.02
60	11	1/4	11 ER 60 W	11 EL 60 W	11 IR 60 W	11 IL 60 W	.03	.02
56	11	1/4	11 ER 56 W	11 EL 56 W	11 IR 56 W	11 IL 56 W	.03	.02
48	11	1/4	11 ER 48 W	11 EL 48 W	11 IR 48 W	11 IL 48 W	.02	.02
40	11	1/4	11 ER 40 W	11 EL 40 W	11 IR 40 W	11 IL 40 W	.02	.02
36	11	1/4	11 ER 36 W	11 EL 36 W	11 IR 36 W	11 IL 36 W	.02	.02
32	11	1/4	11 ER 32 W	11 EL 32 W	11 IR 32 W	11 IL 32 W	.02	.02
28	11	1/4	11 ER 28 W	11 EL 28 W	11 IR 28 W	11 IL 28 W	.02	.03
26	11	1/4	11 ER 26 W	11 EL 26 W	11 IR 26 W	11 IL 26 W	.03	.03
24	11	1/4	11 ER 24 W	11 EL 24 W	11 IR 24 W	11 IL 24 W	.03	.03
22	11	1/4	11 ER 22 W	11 EL 22 W	11 IR 22 W	11 IL 22 W	.03	.04
20	11	1/4	11 ER 20 W	11 EL 20 W	11 IR 20 W	11 IL 20 W	.03	.04
19	11	1/4	11 ER 19 W	11 EL 19 W	11 IR 19 W	11 IL 19 W	.03	.04
18	11	1/4	11 ER 18 W	11 EL 18 W	11 IR 18 W	11 IL 18 W	.03	.04
16	11	1/4	11 ER 16 W	11 EL 16 W	11 IR 16 W	11 IL 16 W	.04	.04
14	11	1/4	11 ER 14 W	11 EL 14 W	11 IR 14 W	11 IL 14 W	.04	.04
12	11	1/4			11 IR 12 W	11 IL 12 W	.04	.04
11	11	1/4			⁽¹⁾ 11 IR 11 W	⁽¹⁾ 11 IL 11 W	.04	.05
72	16	3/8	16 ER 72 W	16 EL 72 W	16 IR 72 W	16 IL 72 W	.03	.02
60	16	3/8	16 ER 60 W	16 EL 60 W	16 IR 60 W	16 IL 60 W	.03	.02
56	16	3/8	16 ER 56 W	16 EL 56 W	16 IR 56 W	16 IL 56 W	.03	.02
48	16	3/8	16 ER 48 W	16 EL 48 W	16 IR 48 W	16 IL 48 W	.02	.02
40	16	3/8	16 ER 40 W	16 EL 40 W	16 IR 40 W	16 IL 40 W	.02	.02
36	16	3/8	16 ER 36 W	16 EL 36 W	16 IR 36 W	16 IL 36 W	.02	.02
32	16	3/8	16 ER 32 W	16 EL 32 W	16 IR 32 W	16 IL 32 W	.02	.02
28	16	3/8	16 ER 28 W	16 EL 28 W	16 IR 28 W	16 IL 28 W	.02	.03
26	16	3/8	16 ER 26 W	16 EL 26 W	16 IR 26 W	16 IL 26 W	.03	.03
24	16	3/8	16 ER 24 W	16 EL 24 W	16 IR 24 W	16 IL 24 W	.03	.03

(1) Special holder is required or standard holder can be amended by customer. →

Thread Turning Inserts

Whitworth - 55° BSW, BSF, BSP, BSB

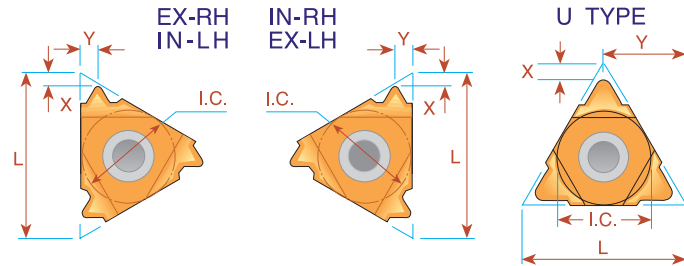
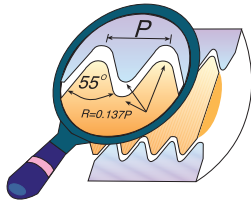

Pitch TPI	L mm	I.C.	EXTERNAL		INTERNAL		X	Y
			Right Hand	Left Hand	Right Hand	Left Hand		
22	16	3/8	16 ER 22 W	16 EL 22 W	16 IR 22 W	16 IL 22 W	.03	.04
20	16	3/8	16 ER 20 W	16 EL 20 W	16 IR 20 W	16 IL 20 W	.03	.04
19	16	3/8	16 ER 19 W	16 EL 19 W	16 IR 19 W	16 IL 19 W	.03	.04
18	16	3/8	16 ER 18 W	16 EL 18 W	16 IR 18 W	16 IL 18 W	.03	.04
16	16	3/8	16 ER 16 W	16 EL 16 W	16 IR 16 W	16 IL 16 W	.04	.04
14	16	3/8	16 ER 14 W	16 EL 14 W	16 IR 14 W	16 IL 14 W	.04	.05
12	16	3/8	16 ER 12 W	16 EL 12 W	16 IR 12 W	16 IL 12 W	.04	.06
11	16	3/8	16 ER 11 W	16 EL 11 W	16 IR 11 W	16 IL 11 W	.04	.06
10	16	3/8	16 ER 10 W	16 EL 10 W	16 IR 10 W	16 IL 10 W	.04	.06
9	16	3/8	16 ER 9 W	16 EL 9 W	16 IR 9 W	16 IL 9 W	.05	.07
8	16	3/8	16 ER 8 W	16 EL 8 W	16 IR 8 W	16 IL 8 W	.05	.06
7	22	1/2	22 ER 7 W	22 EL 7 W	22 IR 7 W	22 IL 7 W	.06	.09
6	22	1/2	22 ER 6 W	22 EL 6 W	22 IR 6 W	22 IL 6 W	.06	.09
5	22	1/2	22 ER 5 W	22 EL 5 W	22 IR 5 W	22 IL 5 W	.07	.09
4.5	22U	1/2U	22U E/I/R/L 4.5 W				.09	.43
4	22U	1/2U	22U E/I/R/L 4 W				.07	.43
4.5	27	5/8	27 ER 4.5 W	27 EL 4.5 W	27 IR 4.5 W	27 IL 4.5 W	.07	.10
4	27	5/8	27 ER 4 W	27 EL 4 W	27 IR 4 W	27 IL 4 W	.08	.11
3.5	27U	5/8U	27U E/I/R/L 3.5 W				.08	.54
3.25	27U	5/8U	27U E/I/R/L 3.25 W				.08	.54
3	27U	5/8U	27U E/I/R/L 3 W				.09	.54
2.75	27U	5/8U	27U E/I/R/L 2.75 W				.09	.54
*2.625	27U	5/8U	27U E/I/R/L 2.625 W				.10	.54
*2.5	27U	5/8U	27U E/I/R/L 2.5 W				.11	.54

Order example: 16 IR 18 W BMA

For carbide grade and cutting speed see page A04-2 and 3

Whitworth - 55° BSW, BSF, BSP, BSB

Type B

Ground Profile with Sintered Chip-breaker

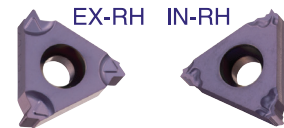

Pitch TPI	L mm	I.C.	EXTERNAL	INTERNAL	X	Y
			Ordering Code Right Hand	Ordering Code Right Hand		
28	11	1/4		11 IR B 28 W	.02	.02
24	11	1/4		11 IR B 24 W	.02	.02
20	11	1/4		11 IR B 20 W	.03	.04
19	11	1/4		11 IR B 19 W	.03	.04
18	11	1/4		11 IR B 18 W	.03	.04
16	11	1/4		11 IR B 16 W	.03	.04
14	11	1/4		11 IR B 14 W	.03	.04
19	16	3/8	16 ER B 19 W	16 IR B 19 W	.03	.04
16	16	3/8	16 ER B 16 W	16 IR B 16 W	.04	.04
14	16	3/8	16 ER B 14 W	16 IR B 14 W	.04	.05
11	16	3/8	16 ER B 11 W	16 IR B 11 W	.04	.06
10	16	3/8	16 ER B 10 W	16 IR B 10 W	.04	.06

Order example: 16 IR B 10 W BMA

Vertical

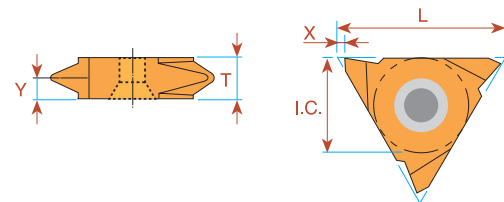

Pitch TPI	L mm	I.C.	EXTERNAL	EXTERNAL	X	Y	T
			Ordering Code Right Hand	Ordering Code Left Hand			
20	16	3/8	16V ER 20 W	16V EL 20 W	.04	.04	.14
19	16	3/8	16V ER 19 W	16V EL 19 W	.04	.04	.14
18	16	3/8	16V ER 18 W	16V EL 18 W	.04	.04	.14
16	16	3/8	16V ER 16 W	16V EL 16 W	.04	.04	.14
14	16	3/8	16V ER 14 W	16V EL 14 W	.04	.05	.14
12	16	3/8	16V ER 12 W	16V EL 12 W	.04	.05	.14
11	16	3/8	16V ER 11 W	16V EL 11 W	.04	.06	.14

Order example: 16V ER 14 W MXC

Thread Turning Inserts

Multitooth

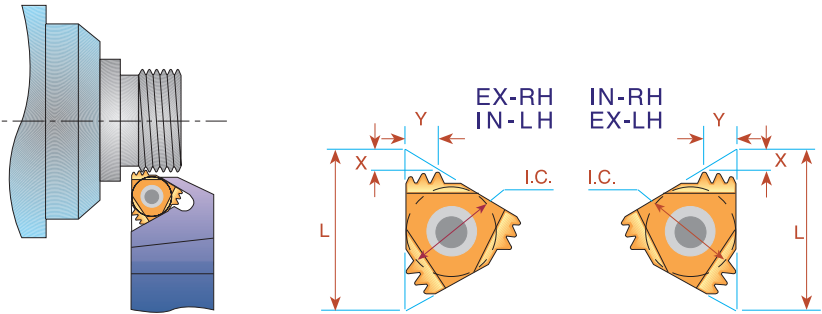

Pitch TPI	L mm	I.C.	Number of Teeth	EXTERNAL Ordering Code	Anvil	INTERNAL Ordering Code	Anvil	X	Y
14	16	3/8	2	16 ER 14 W 2M	AE16M	16 IR 14 W 2M	AI16M	.07	.11
14	22	1/2	3	22 ER 14 W 3M	AE22M	22 IR 14 W 3M	AI22M	.11	.18
11	22	1/2	2	22 ER 11 W 2M	AE22M	22 IR 11 W 2M	AI22M	.09	.13

Order example: 16 ER 14 W 2M MXC
 For recommended number of passes see page A04-4

For carbide grade and cutting speed see page A04-2 and 3

NPT

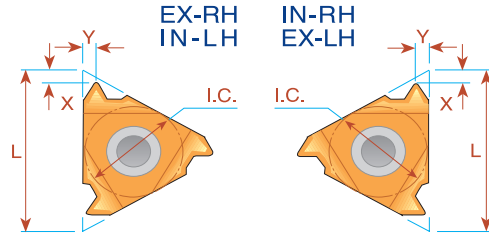
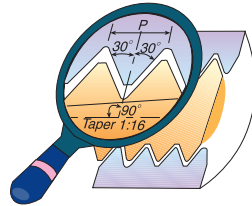

Pitch TPI	L mm	I.C.	EXTERNAL		INTERNAL		X	Y
			Ordering Code Right Hand	Ordering Code Left Hand	Ordering Code Right Hand	Ordering Code Left Hand		
27	6	5/32	<i>ULTRA MINIATURE</i> →		06 IR 27 NPT	06 IL 27 NPT	.02	.02
27	8	3/16			08 IR 27 NPT	08 IL 27 NPT	.02	.02
18	8	3/16	<i>MINIATURE</i> →		08 IR 18 NPT	08 IL 18 NPT	.02	.02
27	11	1/4	11 ER 27 NPT	11 EL 27 NPT	11 IR 27 NPT	11 IL 27 NPT	.03	.03
18	11	1/4	11 ER 18 NPT	11 EL 18 NPT	11 IR 18 NPT	11 IL 18 NPT	.03	.04
14	11	1/4	11 ER 14 NPT	11 EL 14 NPT	11 IR 14 NPT	11 IL 14 NPT	.03	.04
27	16	3/8	16 ER 27 NPT	16 EL 27 NPT	16 IR 27 NPT	16 IL 27 NPT	.03	.03
18	16	3/8	16 ER 18 NPT	16 EL 18 NPT	16 IR 18 NPT	16 IL 18 NPT	.03	.04
14	16	3/8	16 ER 14 NPT	16 EL 14 NPT	16 IR 14 NPT	16 IL 14 NPT	.04	.05
11.5	16	3/8	16 ER 11.5 NPT	16 EL 11.5 NPT	16 IR 11.5 NPT	16 IL 11.5 NPT	.04	.06
8	16	3/8	16 ER 8 NPT	16 EL 8 NPT	16 IR 8 NPT	16 IL 8 NPT	.05	.07

Order example: 16 ER 14 NPT MXC
For small bore threading see page A06-16

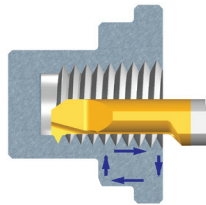

Type B

Ground Profile with Sintered Chip-breaker

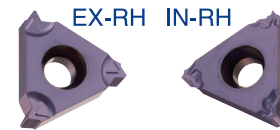

Pitch TPI	L	I.C. mm	EXTERNAL	INTERNAL	X	Y
			Ordering Code Right Hand	Ordering Code Right Hand		
18	11	1/4		11 IR B 18 NPT	.03	.04
18	16	3/8	16 ER B 18 NPT	16 IR B 18 NPT	.03	.04
14	16	3/8	16 ER B 14 NPT	16 IR B 14 NPT	.04	.05
11.5	16	3/8	16 ER B 11.5 NPT	16 IR B 11.5 NPT	.04	.06
8	16	3/8	16 ER B 8 NPT	16 IR B 8 NPT	.05	.07

Order example: 16 IR B 11.5 NPT BMA
For carbide grade and cutting speed see page A04-2 and 3

Thread Turning Inserts

NPT Multitooth

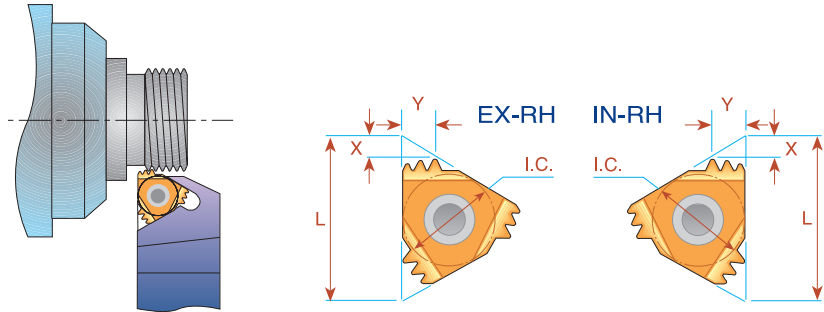

Pitch TPI	L mm	I.C.	Number of Teeth	EXTERNAL Ordering Code	Anvil	INTERNAL Ordering Code	Anvil	X	Y
14	16	3/8	2	16 ER 14 NPT 2M	AE16M	16 IR 14 NPT 2M	AI16M	.07	.11
11.5	22	1/2	2	22 ER 11.5 NPT 2M	AE22M	22 IR 11.5 NPT 2M	AI22M	.09	.14
11.5	27	5/8	3	27 ER 11.5 NPT 3M	AE27M	27 IR 11.5 NPT 3M	AI27M	.13	.22
8	27	5/8	2	27 ER 8 NPT 2M	AE27M	27 IR 8 NPT 2M	AI27M	.12	.20

Order example: 22 ER 11.5 NPT 2M MXC

For recommended number of passes see page A04-4

NPT Vertical

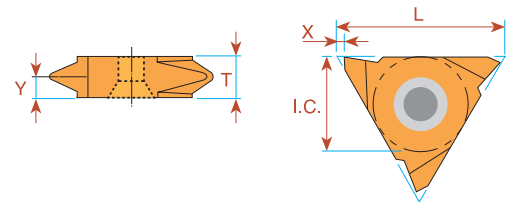

Pitch TPI	L mm	I.C.	EXTERNAL Ordering Code Right Hand	EXTERNAL Ordering Code Left Hand	X	Y	T
27	16	3/8	16V ER 27 NPT	16V EL 27 NPT	.04	.03	.14
18	16	3/8	16V ER 18 NPT	16V EL 18 NPT	.04	.04	.14
14	16	3/8	16V ER 14 NPT	16V EL 14 NPT	.04	.05	.14
11.5	16	3/8	16V ER 11.5 NPT	16V EL 11.5 NPT	.04	.06	.14

Order example: 16V ER 14 NPT BMA

For carbide grade and cutting speed see page A04-2 and 3

NPTF - Dryseal

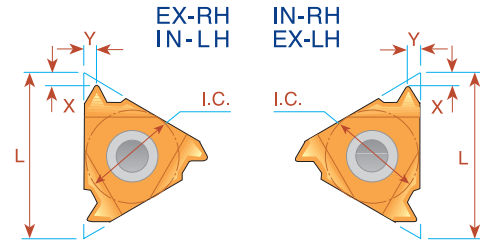
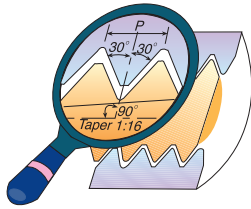

Pitch TPI	L mm	I.C.	EXTERNAL		INTERNAL		X	Y
			Ordering Code		Ordering Code			
			Right Hand	Left Hand	Right Hand	Left Hand		
27	6	5/32	ULTRA MINIATURE →		06 IR 27 NPTF	06 IL 27 NPTF	.03	.02
27	8	3/16			08 IR 27 NPTF	08 IL 27 NPTF	.02	.02
18	8	3/16	MINIATURE →		08 IR 18 NPTF	08 IL 18 NPTF	.02	.02
27	11	1/4	11 ER 27 NPTF	11 EL 27 NPTF	11 IR 27 NPTF	11 IL 27 NPTF	.03	.03
18	11	1/4	11 ER 18 NPTF	11 EL 18 NPTF	11 IR 18 NPTF	11 IL 18 NPTF	.03	.04
14	11	1/4	11 ER 14 NPTF	11 EL 14 NPTF	11 IR 14 NPTF	11 IL 14 NPTF	.03	.04
27	16	3/8	16 ER 27 NPTF	16 EL 27 NPTF	16 IR 27 NPTF	16 IL 27 NPTF	.03	.03
18	16	3/8	16 ER 18 NPTF	16 EL 18 NPTF	16 IR 18 NPTF	16 IL 18 NPTF	.03	.04
14	16	3/8	16 ER 14 NPTF	16 EL 14 NPTF	16 IR 14 NPTF	16 IL 14 NPTF	.04	.05
11.5	16	3/8	16 ER 11.5 NPTF	16 EL 11.5 NPTF	16 IR 11.5 NPTF	16 IL 11.5 NPTF	.04	.06
8	16	3/8	16 ER 8 NPTF	16 EL 8 NPTF	16 IR 8 NPTF	16 IL 8 NPTF	.05	.07

Order example: 11 ER 27 NPTF MXC

Type B

Ground Profile with Sintered Chip-breaker

Pitch TPI	L mm	I.C.	INTERNAL Ordering Code Right Hand	X	Y
18	11	1/4	11 IR B 18 NPTF	.03	.04

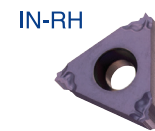

Order example: 11 IR B 18 NPTF BMA

Multitooth

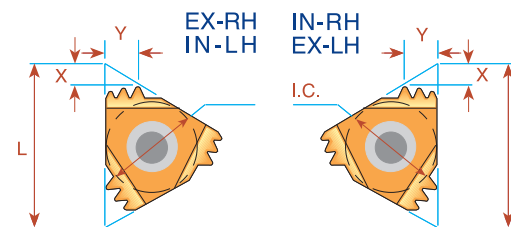
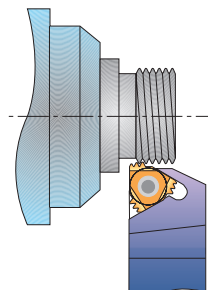

Pitch TPI	L mm	I.C.	Number of Teeth	EXTERNAL Ordering Code	Anvil	INTERNAL Ordering Code	Anvil	X	Y
11.5	22	1/2	2	22 ER 11.5 NPTF 2M	AE22M	22 IR 11.5 NPTF 2M	AI22M	.09	0.14

Order example: 22 ER 11.5 NPTF 2M BMA

For carbide grade and cutting speed see page A04-2 and 3

Thread Turning Inserts

BSPT

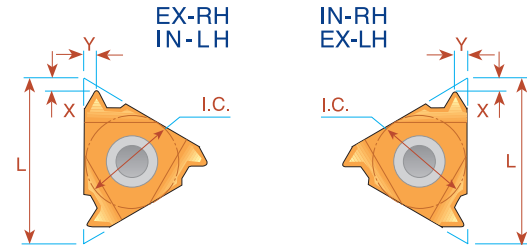
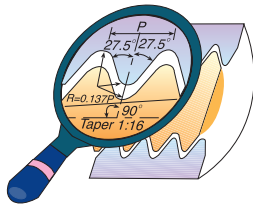

Pitch TPI	L mm	I.C.	EXTERNAL		INTERNAL		X	Y
			Ordering Code Right Hand	Ordering Code Left Hand	Ordering Code Right Hand	Ordering Code Left Hand		
28	6	5/32	<i>ULTRA MINIATURE</i> →		06 IR 28 BSPT	06 IL 28 BSPT	.03	.02
28	8	3/16	<i>MINIATURE</i> →		08 IR 28 BSPT	08 IL 28 BSPT	.02	.02
19	8	3/16			08 IR 19 BSPT	08 IL 19 BSPT	.02	.02
28	11	1/4			11 IR 28 BSPT	11 IL 28 BSPT	.02	.02
19	11	1/4			11 IR 19 BSPT	11 IL 19 BSPT	.03	.04
14	11	1/4			11 IR 14 BSPT	11 IL 14 BSPT	.04	.04
11	11	1/4			⁽¹⁾ 11 IR 11 BSPT	⁽¹⁾ 11 IL 11 BSPT	.04	.05
28	16	3/8	16 ER 28 BSPT	16 EL 28 BSPT	16 IR 28 BSPT	16 IL 28 BSPT	.02	.03
19	16	3/8	16 ER 19 BSPT	16 EL 19 BSPT	16 IR 19 BSPT	16 IL 19 BSPT	.03	.04
14	16	3/8	16 ER 14 BSPT	16 EL 14 BSPT	16 IR 14 BSPT	16 IL 14 BSPT	.04	.05
11	16	3/8	16 ER 11 BSPT	16 EL 11 BSPT	16 IR 11 BSPT	16 IL 11 BSPT	.04	.06

Order example: 11 IR 14 BSPT BMA

(1) Special holder is required or standard holder can be amended by customer.

Type B

Ground Profile with Sintered Chip-breaker

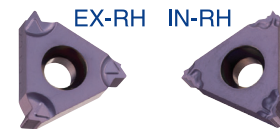

Pitch TPI	L mm	I.C.	EXTERNAL	INTERNAL	X	Y
			Ordering Code Right Hand	Ordering Code Right Hand		
19	11	1/4		11 IR B 19 BSPT	.03	.04
19	16	3/8	16 ER B 19 BSPT		.04	.04
14	16	3/8	16 ER B 14 BSPT	16 IR B 14 BSPT	.05	.04
11	16	3/8	16 ER B 11 BSPT	16 IR B 11 BSPT	.06	.04

Order example: 16 ER B 11 BSPT BMA

For carbide grade and cutting speed see page A04-2 and 3

BSPT Vertical

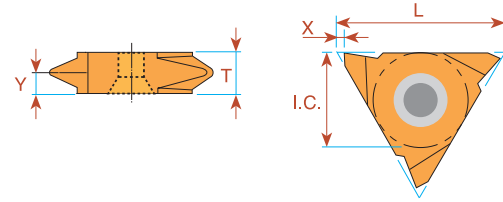

Pitch TPI	L mm	I.C.	EXTERNAL	EXTERNAL	X	Y	T
			Ordering Code Right Hand	Ordering Code Left Hand			
28	16	3/8	16V ER 28 BSPT	16V EL 28 BSPT	.04	.02	.14
19	16	3/8	16V ER 19 BSPT	16V EL 19 BSPT	.04	.04	.14
14	16	3/8	16V ER 14 BSPT	16V EL 14 BSPT	.04	.05	.14
11	16	3/8	16V ER 11 BSPT	16V EL 11 BSPT	.04	.06	.14

Order example: 16V ER 19 BSPT BMA

DIN 477

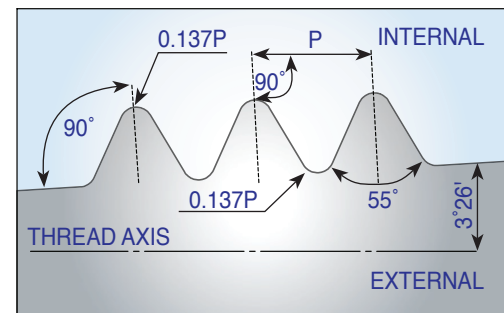

Pitch TPI	L mm	I.C.	Taper Ratio	EXTERNAL	INTERNAL	X	Y	Thread Designation
				Ordering Code Right Hand	Ordering Code Right Hand			
14	16	3/8	3/25	16 ER 14 DIN477		.04	.05	W19.8x1/14 keg(Ext.)
14	11	1/4	3/25		*11 IR 14 DIN477	.04	.04	W19.8x1/14 keg(Int.)
14	16	3/8	3/25	16 ER 14 DIN477	**16 IR 14 DIN477	.04	.05	W28.8x1/14 keg
14	16	3/8	3/25	16 ER 14 DIN477	***16 IR 14 DIN477	.04	.05	W31.3x1/14 keg

* Holder to use: SIR0375H11/SIR0375K11

** Holder to use: SIR0625H16

*** Holder to use: SIR0750P16

Order example: 16 IR 14 DIN477 BMA

For carbide grade and cutting speed see page A04-2 and 3

Thread Turning Inserts

Acme Semi full profile with breaking corners

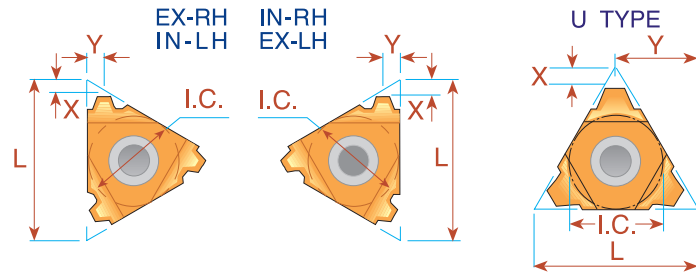
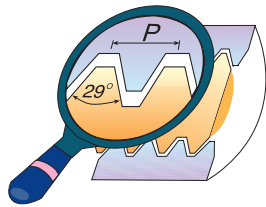

Pitch TPI	L mm	I.C.	EXTERNAL		INTERNAL		X	Y
			Ordering Code Right Hand	Ordering Code Left Hand	Ordering Code Right Hand	Ordering Code Left Hand		
16	8	3/16	MINIATURE		**08 IR 16 ACME	**08 IL 16 ACME	.02	.02
14	8U	3/16U	"U" MINIATURE		08U IR/L 14 ACME		.03	.16
12	8U	3/16U			08U IR/L 12 ACME		.03	.16
10	8U	3/16U			08U IR/L 10 ACME		.03	.16
16	11	1/4	11 ER 16 ACME	11 EL 16 ACME	11 IR 16 ACME	11 IL 16 ACME	.04	.04
16	16	3/8	16 ER 16 ACME	16 EL 16 ACME	16 IR 16 ACME	16 IL 16 ACME	.04	.04
14	16	3/8	16 ER 14 ACME	16 EL 14 ACME	16 IR 14 ACME	16 IL 14 ACME	.04	.05
12	16	3/8	16 ER 12 ACME	16 EL 12 ACME	16 IR 12 ACME	16 IL 12 ACME	.04	.05
10	16	3/8	16 ER 10 ACME	16 EL 10 ACME	16 IR 10 ACME	16 IL 10 ACME	.05	.05
8	16	3/8	16 ER 8 ACME	16 EL 8 ACME	16 IR 8 ACME	16 IL 8 ACME	.06	.05
6	16	3/8	(1)16 ER 6 ACME	(1)16 EL 6 ACME	(1)16 IR 6 ACME	(1)16 IL 6 ACME	.07	.07
6	22	1/2	22 ER 6 ACME	22 EL 6 ACME	22 IR 6 ACME	22 IL 6 ACME	.07	.08
5	22	1/2	22 ER 5 ACME	22 EL 5 ACME	22 IR 5 ACME	22 IL 5 ACME	.08	.09
4	22	1/2	(1)22 ER 4 ACME	(1)22 EL 4 ACME	(1)22 IR 4 ACME	(1)22 IL 4 ACME	.08	.09
4	22U	1/2U	22U ER/L 4 ACME		22U IR/L 4 ACME		.09	.43
4	27	5/8	27 ER 4 ACME	27 EL 4 ACME	27 IR 4 ACME	27 IL 4 ACME	.09	.11
3	27U	5/8U	27U ER/L 3 ACME		27U IR/L 3 ACME		.11	.54
2	33U	3/4U	33U ER/L 2 ACME		33U IR/L 2 ACME		.17	.67

** One cutting edge

Order example: 16 ER 16 ACME MXC

(1) Special holder is required or standard holder can be amended by customer.

Acme Vertical

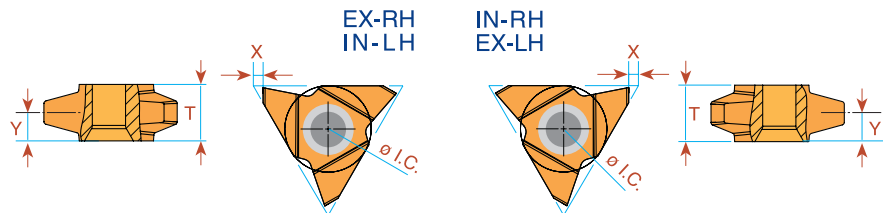

Pitch TPI	L mm	I.C.	EXTERNAL		X	Y	T	INTERNAL		X	Y	T
			Ordering Code Right Hand	Ordering Code Left Hand				Ordering Code Right Hand	Ordering Code Left Hand			
* 3.5	27	5/8	27V ER 3.5 ACME		.07	.20	.41	27V IR 3.5 ACME		.07	.16	.41
** 3	27	5/8	27V ER 3 ACME		.07	.20	.41	27V IR 3 ACME		.07	.18	.41
*** 2	27	5/8	27V ER 2 ACME	27V EL 2 ACME	.07	.20	.41	27V IR 2 ACME	27V IL 2 ACME	.07	.20	.41

* Minimum bore: Ø2.17 ** Minimum bore: Ø2.17 *** Minimum bore: Ø3

Order example: 27V ER 2 ACME BMA

For carbide grade and cutting speed see page A04-2 and 3

Stub Acme

Semi full profile with breaking corners

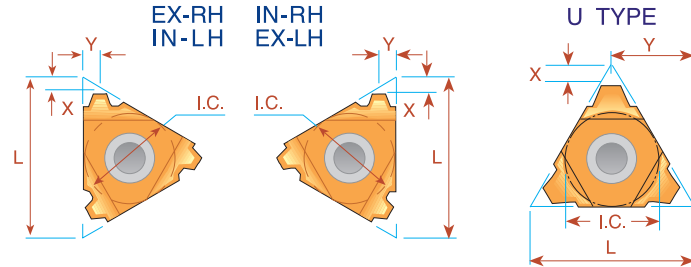
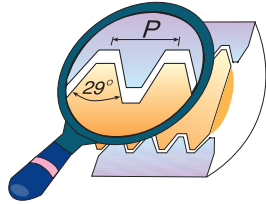

Pitch TPI	L mm	I.C.	EXTERNAL		INTERNAL		X	Y
			Ordering Code		Ordering Code			
			Right Hand	Left Hand	Right Hand	Left Hand		
16	8	3/16	<i>MINIATURE</i> →		**08 IR 16 STACME	**08 IL 16 STACME	.02	.02
14	8U	3/16U	<i>"U" MINIATURE</i> →		08U IR/L 14 STACME		.03	.16
12	8U	3/16U			08U IR/L 12 STACME		.04	.16
10	8U	3/16U			08U IR/L 10 STACME		.04	.16
16	11	1/4	11 ER 16 STACME	11 EL 16 STACME			.04	.04
16	16	3/8	16 ER 16 STACME	16 EL 16 STACME	16 IR 16 STACME	16 IL 16 STACME	.04	.04
14	16	3/8	16 ER 14 STACME	16 EL 14 STACME	16 IR 14 STACME	16 IL 14 STACME	.04	.04
12	16	3/8	16 ER 12 STACME	16 EL 12 STACME	16 IR 12 STACME	16 IL 12 STACME	.05	.05
10	16	3/8	16 ER 10 STACME	16 EL 10 STACME	16 IR 10 STACME	16 IL 10 STACME	.05	.05
8	16	3/8	16 ER 8 STACME	16 EL 8 STACME	16 IR 8 STACME	16 IL 8 STACME	.06	.06
6	16	3/8	16 ER 6 STACME	16 EL 6 STACME	16 IR 6 STACME	16 IL 6 STACME	.07	.07
5	22	1/2	22 ER 6 STACME	22 EL 6 STACME	22 IR 6 STACME	22 IL 6 STACME	.07	.07
5	22	1/2	22 ER 5 STACME	22 EL 5 STACME	22 IR 5 STACME	22 IL 5 STACME	.08	.09
4	22	1/2	22 ER 4 STACME	22 EL 4 STACME	22 IR 4 STACME	22 IL 4 STACME	.09	.09
4	22U	1/2U	22U ER/L 4 STACME		22U IR/L 4 STACME		.10	.43
3	22U	1/2U	22U ER/L 3 STACME		22U IR/L 3 STACME		.13	.43
4	27	5/8	27 ER 4 STACME	27 EL 4 STACME	27 IR 4 STACME	27 IL 4 STACME	.09	.09
3	27	5/8	27 ER 3 STACME	27 EL 3 STACME	27 IR 3 STACME	27 IL 3 STACME	.11	.11
2	33U	3/4U	33U ER/L 2 STACME		33U IR/L 2 STACME		.20	.67

** One cutting edge

Order example: 22 IR 5 STACME MXC

For carbide grade and cutting speed see page A04-2 and 3

Thread Turning Inserts

Trapez - DIN 103 Semi full profile with breaking corners

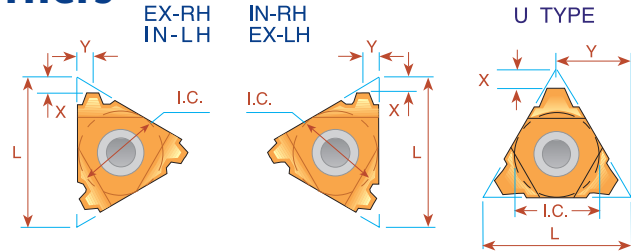
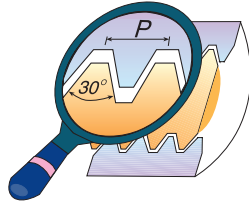

Pitch mm	L mm	I.C.	EXTERNAL Ordering Code		INTERNAL Ordering Code		X	Y
			Right Hand	Left Hand	Right Hand	Left Hand		
1.5	8	3/16	MINIATURE →		**08 IR 1.5 TR	**08 IL 1.5 TR	.02	.02
2.0	8U	3/16U	"U" MINIATURE →		08U IR/L 2 TR		.04	.16
1.5	16	3/8	16 ER 1.5 TR	16 EL 1.5 TR	16 IR 2 TR	16 IL 2 TR	.04	.04
2.0	16	3/8	16 ER 2 TR	16 EL 2 TR			.04	.05
3.0	16	3/8	16 ER 3 TR	16 EL 3 TR	16 IR 3 TR	16 IL 3 TR	.05	.06
4.0	16	3/8	(1)16 ER 4 TR	(1)16 EL 4 TR	(1)16 IR 4 TR	(1)16 IL 4 TR	.05	.06
4.0	22	1/2	22 ER 4 TR	22 EL 4 TR	22 IR 4 TR	22 IL 4 TR	.07	.07
5.0	22	1/2	22 ER 5 TR	22 EL 5 TR	22 IR 5 TR	22 IL 5 TR	.08	.09
6.0	22	1/2	(1)22 ER 6 TR	(1)22 EL 6 TR	(1)22 IR 6 TR	(1)22 IL 6 TR	.08	.09
6.0	22U	1/2U	22U ER/L 6 TR		22U IR/L 6 TR		.08	.43
7.0	22U	1/2U	22U ER/L 7 TR		22U IR/L 7 TR		.09	.43
8.0	22U	1/2U	22U ER/L 8 TR		22U IR/L 8 TR		.10	.43
6.0	27	5/8	27 ER 6 TR	27 EL 6 TR	27 IR 6 TR	27 IL 6 TR	.09	.11
7.0	27	5/8	27 ER 7 TR	27 EL 7 TR	27 IR 7 TR	27 IL 7 TR	.09	.10
8.0	27U	5/8U	27U ER/L 8 TR		27U IR/L 8 TR		.10	.54
9.0	27U	5/8U	27U ER/L 9 TR		27U IR/L 9 TR		.12	.54
10.0	27U	5/8U	**27U ER/L 10 TR		**27U IR/L 10 TR		.13	.54
12.0	33U	3/4U	33U ER/L 12 TR		33U IR/L 12 TR		.15	.67

Order example: 22 IR 5 TR MXC

** One cutting edge

(1) Special holder is required or standard holder can be amended by customer.

Trapez - DIN 103 Vertical

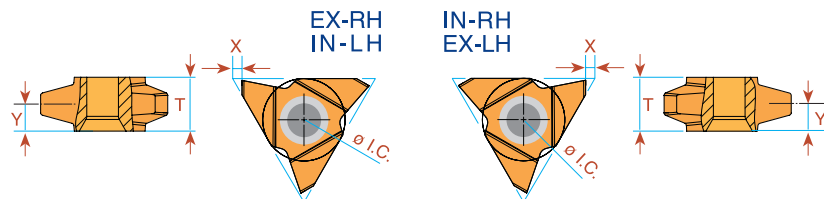

Pitch mm	L mm	I.C.	EXTERNAL Ordering Code		INTERNAL Ordering Code		X	Y	T
			Right Hand	Left Hand	Right Hand	Left Hand			
* 9	27	5/8	27V ER 9 TR	27V EL 9 TR	27V IR 9 TR	27V IL 9 TR	.07	.21	.41
** 10	27	5/8	27V ER 10 TR	27V EL 10 TR	27V IR 10 TR	27V IL 10 TR	.07	.21	.41
*** 12	27	5/8	27V ER 12 TR	27V EL 12 TR	27V IR 12 TR	27V IL 12 TR	.07	.21	.41

Order example: 27V ER 10 TR BMA

* Minimum bore: Ø2.56 ** Minimum bore: Ø2.56 *** Minimum bore: Ø2.87

For carbide grade and cutting speed see page A04-2 and 3

PG - DIN 40430

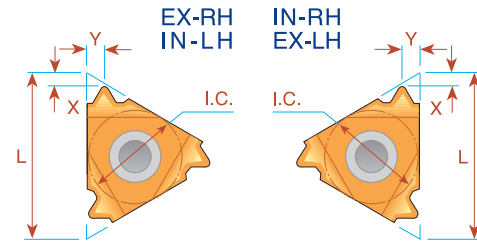
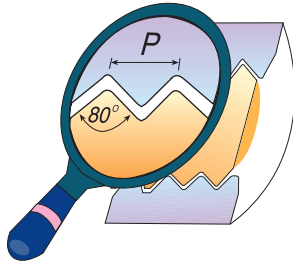

Pitch TPI	L mm	I.C.	EXTERNAL		INTERNAL		X	Y
			Right Hand	Standard	Right Hand	Standard		
20	8	3/16	MINIATURE →		08 IR 20 PG	(PG 7)	.02	.03
18	11	1/4			11 IR 18 PG	(PG 9)	.03	.04
20	16	3/8	16 ER 20 PG	(PG 7)	16 IR 18 PG	(PG 11, 13.5, 16)	.03	.03
18	16	3/8	16 ER 18 PG	(PG 9, 11, 13.5, 16)			.03	.04
16	16	3/8	16 ER 16 PG	(PG 21, 29, 36, 42, 48)			16 IR 16 PG	(PG 21, 29, 36, 42, 48)

Order example: 16 ER 16 PG BMA

Sagengewinde- DIN 513

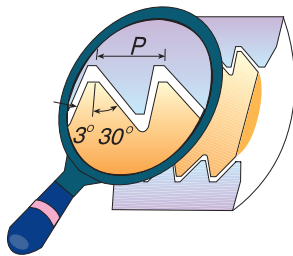

IMPORTANT NOTE:
In Carmex standard execution, the flank with the large angle is the leading edge. If otherwise required, please specify in your order.

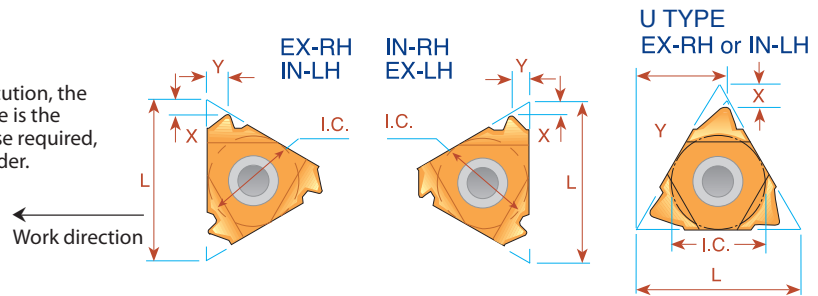

Pitch mm	L mm	I.C.	EXTERNAL		X	Y	INTERNAL		X	Y
			Right Hand	Left Hand			Right Hand	Left Hand		
2.0	16	3/8	16 ER 2 SAGE	16 EL 2 SAGE	.04	.06	16 IR 2 SAGE	16 IL 2 SAGE	.05	.07
**3.0	22	1/2	22 ER 3 SAGE	22 EL 3 SAGE	.06	.09	22 IR 3 SAGE	22 IL 3 SAGE	.07	.11
**4.0	22	1/2	22 ER 4 SAGE	22 EL 4 SAGE	.07	.12	22 IR 4 SAGE	22 IL 4 SAGE	.09	.14
*5.0	22U	1/2U	22U ER 5 SAGE	22U EL 5 SAGE	.05	.46	22U IR 5 SAGE	22U IL 5 SAGE	.07	.46
*6.0	22U	1/2U	22U ER 6 SAGE	22U EL 6 SAGE	.05	.46	22U IR 6 SAGE	22U IL 6 SAGE	.08	.47

* Requires a special anvil AER 22U-1.5 SAGE 5/6, AEL 22U-1.5 SAGE 5/6, AIR 22U-1.5 SAGE 5/6, AIL 22U-1.5 SAGE 5/6

** Requires a special anvil AER 22-1.5 SAGE 3/4, AEL 22-1.5 SAGE 3/4, AIR 22-1.5 SAGE 3/4, AIL 22-1.5 SAGE 3/4

Order example: 22 IR 4 SAGE BMA

For carbide grade and cutting speed see page A04-2 and 3

Thread Turning Inserts

Round - DIN 405

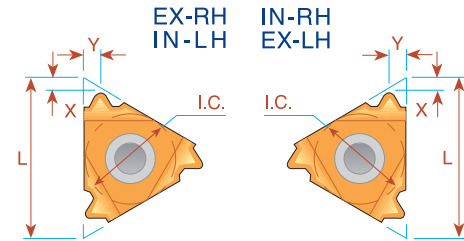
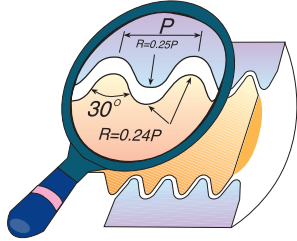

Pitch TPI	L mm	I.C.	EXTERNAL		X	Y	INTERNAL		X	Y
			Ordering Code Right Hand	Ordering Code Left Hand			Ordering Code Right Hand	Ordering Code Left Hand		
10	16	3/8	16 ER 10 RD	16 EL 10 RD	.04	.05	16 IR 10 RD	16 IL 10 RD	.04	.05
8	16	3/8	16 ER 8 RD	16 EL 8 RD	.06	.05	16 IR 8 RD	16 IL 8 RD	.06	.06
6	16	3/8	16 ER 6 RD	16 EL 6 RD	.06	.07	16 IR 6 RD	16 IL 6 RD	.06	.06
6	22	1/2	22 ER 6 RD	22 EL 6 RD	.06	.07	22 IR 6 RD	22 IL 6 RD	.06	.07
4	22	1/2	22 ER 4 RD	22 EL 4 RD	.09	.09	22 IR 4 RD	22 IL 4 RD	.09	.09
4	27	5/8	27 ER 4 RD	27 EL 4 RD	.09	.09	27 IR 4 RD	27 IL 4 RD	.09	.09

Order example: 27 IL 4 RD BMA

Round - DIN 20400

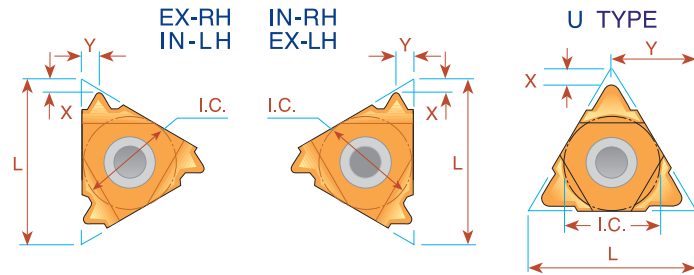
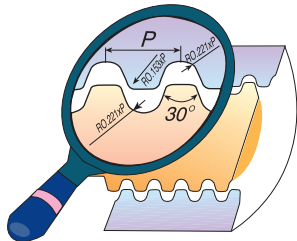

Pitch mm	L mm	I.C.	EXTERNAL	INTERNAL	X	Y
			Ordering Code Right Hand	Ordering Code Right Hand		
4.0	22	1/2	22 ER 4.0 RD 20400	22 IR 4.0 RD 20400	.06	.06
5.0	22	1/2	22 ER 5.0 RD 20400	22 IR 5.0 RD 20400	.07	.07
6.0	22	1/2	22 ER 6.0 RD 20400	22 IR 6.0 RD 20400	.07	.08
8.0	27U	5/8U	*27U E/R/L 8.0 RD 20400		.12	.54
10.0	27U	5/8U	*27U E/R/L 10.0 RD 20400		.13	.54
12.0	33U	3/4U	*33U E/R/L 12.0 RD 20400		.17	.67

* Same insert for Internal and External Right Hand Thread
Order example: 22 ER 4.0 RD 20400 MXC

For carbide grade and cutting speed see page A04-2 and 3

UNJ UNJC, UNJF, UNJEF, UNJS

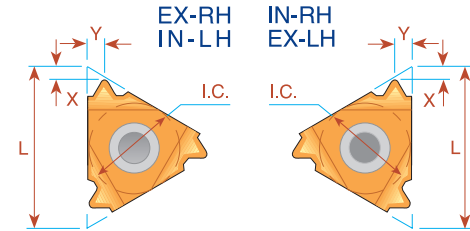
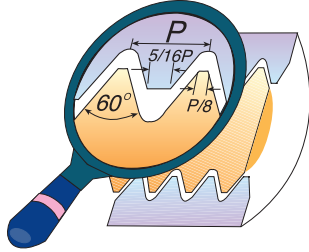

Pitch TPI	L mm	I.C.	EXTERNAL		INTERNAL		X	Y
			Ordering Code Right Hand	Ordering Code Left Hand	Ordering Code Right Hand	Ordering Code Left Hand		
28	08	3/16			08 IR 28 UNJ	08 IL 28 UNJ	.02	.02
24	08	3/16	<i>MINIATURE</i> →		08 IR 24 UNJ	08 IL 24 UNJ	.02	.02
20	08	3/16			08 IR 20 UNJ	08 IL 20 UNJ	.02	.03
18	08	3/16			08 IR 18 UNJ	08 IL 18 UNJ	.02	.03
13	08U	3/16U		<i>"U" MINIATURE</i> →	08 UIR/L 13 UNJ		.04	.16
48	11	1/4	11 ER 48 UNJ	11 EL 48 UNJ	11 IR 48 UNJ	11 IL 48 UNJ	.02	.02
44	11	1/4	11 ER 44 UNJ	11 EL 44 UNJ	11 IR 44 UNJ	11 IL 44 UNJ	.02	.02
40	11	1/4	11 ER 40 UNJ	11 EL 40 UNJ	11 IR 40 UNJ	11 IL 40 UNJ	.02	.02
36	11	1/4	11 ER 36 UNJ	11 EL 36 UNJ	11 IR 36 UNJ	11 IL 36 UNJ	.02	.02
32	11	1/4	11 ER 32 UNJ	11 EL 32 UNJ	11 IR 32 UNJ	11 IL 32 UNJ	.02	.02
28	11	1/4	11 ER 28 UNJ	11 EL 28 UNJ	11 IR 28 UNJ	11 IL 28 UNJ	.02	.02
24	11	1/4	11 ER 24 UNJ	11 EL 24 UNJ	11 IR 24 UNJ	11 IL 24 UNJ	.03	.03
20	11	1/4	11 ER 20 UNJ	11 EL 20 UNJ	11 IR 20 UNJ	11 IL 20 UNJ	.03	.04
18	11	1/4	11 ER 18 UNJ	11 EL 18 UNJ	11 IR 18 UNJ	11 IL 18 UNJ	.03	.04
16	11	1/4	11 ER 16 UNJ	11 EL 16 UNJ	11 IR 16 UNJ	11 IL 16 UNJ	.03	.04
14	11	1/4	11 ER 14 UNJ	11 EL 14 UNJ	11 IR 14 UNJ	11 IL 14 UNJ	.04	.04
48	16	3/8	16 ER 48 UNJ	16 EL 48 UNJ	16 IR 48 UNJ	16 IL 48 UNJ	.02	.02
44	16	3/8	16 ER 44 UNJ	16 EL 44 UNJ	16 IR 44 UNJ	16 IL 44 UNJ	.02	.02
40	16	3/8	16 ER 40 UNJ	16 EL 40 UNJ	16 IR 40 UNJ	16 IL 40 UNJ	.02	.02
36	16	3/8	16 ER 36 UNJ	16 EL 36 UNJ	16 IR 36 UNJ	16 IL 36 UNJ	.02	.02
32	16	3/8	16 ER 32 UNJ	16 EL 32 UNJ	16 IR 32 UNJ	16 IL 32 UNJ	.02	.02
28	16	3/8	16 ER 28 UNJ	16 EL 28 UNJ	16 IR 28 UNJ	16 IL 28 UNJ	.02	.02
24	16	3/8	16 ER 24 UNJ	16 EL 24 UNJ	16 IR 24 UNJ	16 IL 24 UNJ	.03	.03
20	16	3/8	16 ER 20 UNJ	16 EL 20 UNJ	16 IR 20 UNJ	16 IL 20 UNJ	.03	.04
18	16	3/8	16 ER 18 UNJ	16 EL 18 UNJ	16 IR 18 UNJ	16 IL 18 UNJ	.03	.04
16	16	3/8	16 ER 16 UNJ	16 EL 16 UNJ	16 IR 16 UNJ	16 IL 16 UNJ	.03	.04
14	16	3/8	16 ER 14 UNJ	16 EL 14 UNJ	16 IR 14 UNJ	16 IL 14 UNJ	.04	.05
13	16	3/8	16 ER 13 UNJ	16 EL 13 UNJ	16 IR 13 UNJ	16 IL 13 UNJ	.04	.05
12	16	3/8	16 ER 12 UNJ	16 EL 12 UNJ	16 IR 12 UNJ	16 IL 12 UNJ	.04	.06
11	16	3/8	16 ER 11 UNJ	16 EL 11 UNJ	16 IR 11 UNJ	16 IL 11 UNJ	.04	.06
10	16	3/8	16 ER 10 UNJ	16 EL 10 UNJ	16 IR 10 UNJ	16 IL 10 UNJ	.04	.06
9	16	3/8	16 ER 9 UNJ	16 EL 9 UNJ	16 IR 9 UNJ	16 IL 9 UNJ	.05	.06
8	16	3/8	16 ER 8 UNJ	16 EL 8 UNJ	16 IR 8 UNJ	16 IL 8 UNJ	.05	.06

Order example: 16 IR 16 UNJ MXC

For carbide grade and cutting speed see page A04-2 and 3

Thread Turning Inserts

UNJ UNJC, UNJF, UNJEF, UNJS

Type B

Ground Profile with Sintered Chip-breaker

Pitch TPI	L mm	I.C.	INTERNAL Ordering Code Right Hand	X	Y
32	11	1/4	11 IR B 32 UNJ	.02	.02
28	11	1/4	11 IR B 28 UNJ	.02	.02
24	11	1/4	11 IR B 24 UNJ	.02	.02
20	11	1/4	11 IR B 20 UNJ	.03	.04
18	11	1/4	11 IR B 18 UNJ	.03	.04
16	11	1/4	11 IR B 16 UNJ	.03	.04
14	11	1/4	11 IR B 14 UNJ	.03	.04

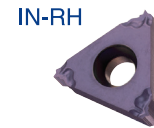

Order example: 11 IR B 20 UNJ BMA

Multitooth

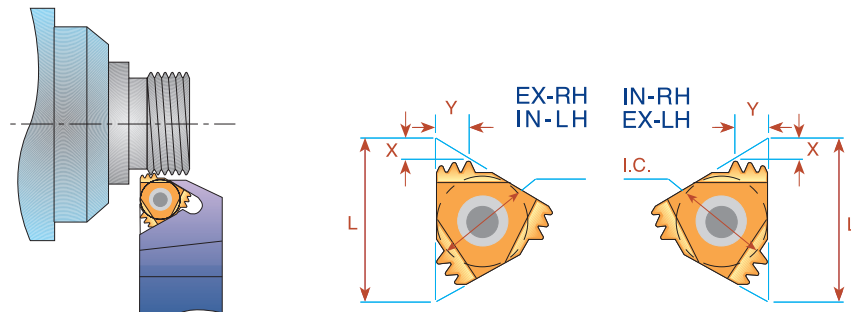

Pitch TPI	L mm	I.C.	Number of Teeth	EXTERNAL Ordering Code	Anvil	INTERNAL Ordering Code	Anvil	X	Y
16	16	3/8	2	16 ER 16 UNJ 2M	AE16M	-	-	.06	.09
16	22	1/2	3	22 ER 16 UNJ 2M	AE22M	-	-	.09	.15

Order example: 22 ER 16 UNJ 2M BMA

For carbide grade and cutting speed see page A04-2 and 3

MJ - ISO 5855

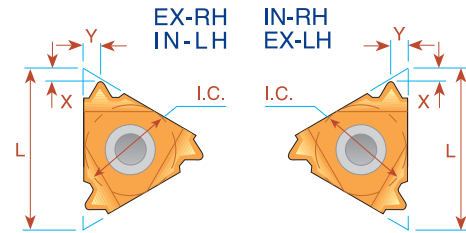
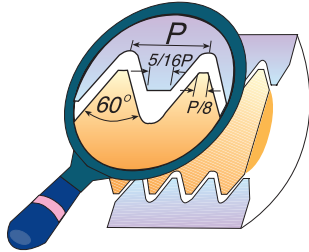

Pitch mm	L mm	I.C.	EXTERNAL	INTERNAL	X	Y
			Ordering Code Right Hand	Ordering Code Right Hand		
0.5	11	1/4		11 IR 0.5 MJ	.02	.02
0.7	11	1/4		11 IR 0.7 MJ	.02	.02
0.75	11	1/4		11 IR 0.75 MJ	.02	.02
0.8	11	1/4		11 IR 0.8 MJ	.02	.02
1.0	11	1/4	11 ER 1.0 MJ	11 IR 1.0 MJ	.03	.03
1.25	11	1/4	11 ER 1.25 MJ	11 IR 1.25 MJ	.03	.04
1.5	11	1/4	11 ER 1.5 MJ	11 IR 1.5 MJ	.03	.04
2.0	11	1/4		11 IR 2.0 MJ	.04	.04
0.5	16	3/8	16 ER 0.5 MJ		.02	.02
0.7	16	3/8	16 ER 0.7 MJ		.02	.02
0.75	16	3/8	16 ER 0.75 MJ	16 IR 0.75 MJ	.02	.02
0.8	16	3/8	16 ER 0.8 MJ	16 IR 0.8 MJ	.02	.02
1.0	16	3/8	16 ER 1.0 MJ	16 IR 1.0 MJ	.03	.03
1.25	16	3/8	16 ER 1.25 MJ	16 IR 1.25 MJ	.03	.04
1.5	16	3/8	16 ER 1.5 MJ	16 IR 1.5 MJ	.03	.04
1.75	16	3/8	16 ER 1.75 MJ	16 IR 1.75 MJ	.04	.04
2.0	16	3/8	16 ER 2.0 MJ	16 IR 2.0 MJ	.04	.05
3.0	16	3/8	16 ER 3.0 MJ	16 IR 3.0 MJ	.05	.06

Order example: 16 ER 1.5 MJ BMA

Type B

Ground Profile with Sintered Chip-breaker

Pitch mm	L mm	I.C.	INTERNAL	X	Y
			Ordering Code Right Hand		
1.0	11	1/4	11 IR B 1.0 MJ	.02	.02
1.5			11 IR B 1.5 MJ	.03	.04

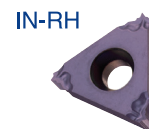

Order example: 11 IR B 1.5 MJ BMA

For carbide grade and cutting speed see page A04-2 and 3

Thread Turning Inserts

American Buttress

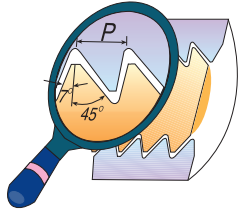

IMPORTANT NOTE:
In Carmex standard execution, the flank with the large angle is the leading edge. If otherwise required, please specify in your order.

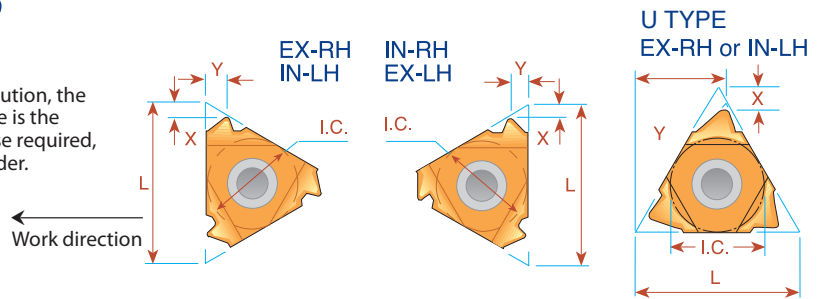

Pitch TPI	L mm	I.C.	EXTERNAL		INTERNAL		X	Y
			Right Hand	Left Hand	Right Hand	Left Hand		
20	11	1/4	11 ER 20 ABUT	11 EL 20 ABUT	11 IR 20 ABUT	11 IL 20 ABUT	.04	.05
16	11	1/4	11 ER 16 ABUT	11 EL 16 ABUT	11 IR 16 ABUT	11 IL 16 ABUT	.04	.06
20	16	3/8	16 ER 20 ABUT	16 EL 20 ABUT	16 IR 20 ABUT	16 IL 20 ABUT	.04	.05
16	16	3/8	16 ER 16 ABUT	16 EL 16 ABUT	16 IR 16 ABUT	16 IL 16 ABUT	.04	.06
12	16	3/8	16 ER 12 ABUT	16 EL 12 ABUT	16 IR 12 ABUT	16 IL 12 ABUT	.06	.08
10	16	3/8	16 ER 10 ABUT	16 EL 10 ABUT	16 IR 10 ABUT	16 IL 10 ABUT	.06	.09
8	22	1/2	22 ER 8 ABUT	22 EL 8 ABUT	22 IR 8 ABUT	22 IL 8 ABUT	.08	.13
6	22	1/2	22 ER 6 ABUT	22 EL 6 ABUT	22 IR 6 ABUT	22 IL 6 ABUT	.08	.13
(1) 4	22U	1/2U	22UER 4 ABUT	22UEL 4 ABUT	22UIR 4 ABUT	22UIL 4 ABUT	.09	.37
(3) 5	27	5/8	27 ER 5 ABUT	27 EL 5 ABUT	27 IR 5 ABUT	27 IL 5 ABUT	.11	.18
(2) 3	27U	5/8U	27UER 3 ABUT	27UEL 3 ABUT	27UIR 3 ABUT	27UIL 3 ABUT	.12	.46

Order example: 16 IL 12 ABUT MXC

Most applications requires anvil change in toolholder see page A04-7

(1) Requires a special anvil AE 22U-1.5 ABUT4, AI22U-1.5 ABUT4

(2) Requires a special anvil AE 27U-1.5 ABUT3, AI27U-1.5 ABUT3

(3) Requires a special anvil AE 27-1.5 ABUT5, AI27-1.5 ABUT5

Multitooth

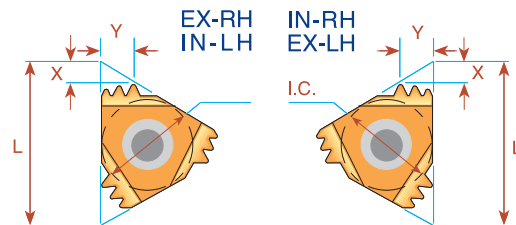
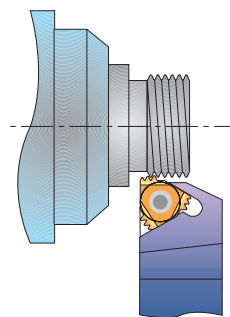

Pitch TPI	L mm	I.C.	Number of Teeth	EXTERNAL	Anvil	INTERNAL	Anvil	X	Y
				Ordering Code		Ordering Code			
12	22	1/2	2	22 ER 12 ABUT 2M	AE22M	22 IR 16 ABUT 2M	AI22M	.10	.16

Order example: 22 IR 16 ABUT 2M BMA

For carbide grade and cutting speed see page A04-2 and 3

American Buttress Vertical

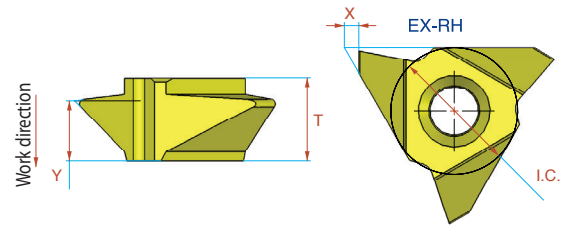

Pitch TPI	L mm	I.C.	EXTERNAL			INTERNAL				
			Ordering Code Right Hand	X	Y	T	Ordering Code Right Hand	X	Y	T
* 4	27	5/8	*27V ER 4 ABUT	.07	.30	.41	27V IR 4 ABUT	.07	.30	.41
** 3	27	5/8	*27V ER 3 ABUT	.07	.30	.41	27V IR 3 ABUT	.07	.24	.41

* For EXT. RH use only holders SER 1000M27V-ABUT 4/3-T10, SER1250P27V-ABUT 4/3-T10

* Minimum bore: Ø2.17

** Minimum bore: Ø2.76

For Carbide Grade and Cutting Speed see page A04 - 2-3

A01-32

Thread Turning Inserts

Threading Tools for the Oil & Gas Industries

API Round

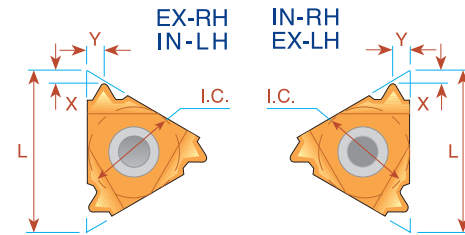
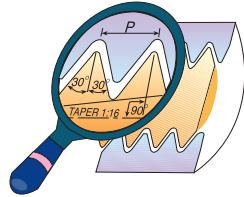

Pitch TPI	L mm	I.C.	Taper IPF	EXTERNAL Ordering Code Right Hand	INTERNAL Ordering Code Right Hand	X	Y
10	16	3/8	.75	16 ER 10 API RD	16 IR 10 API RD	.06	.06
8	16	3/8	.75	16 ER 8 API RD	16 IR 8 API RD	.05	.06

Order example: 16 ER 10 API RD BMA

Multitooth

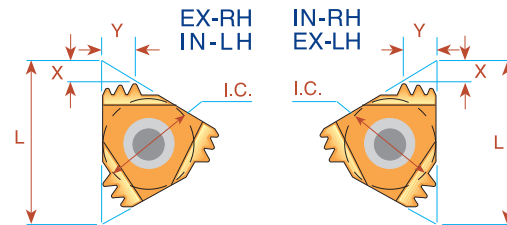
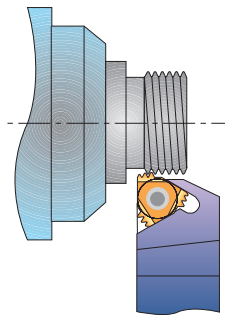

Pitch TPI	L mm	I.C.	Number of Teeth	EXTERNAL Ordering Code	Anvil	INTERNAL Ordering Code	Anvil	X	Y
10	22	1/2	2	22 ER 10API RD 2M	AE22M	22 IR 10API RD 2M	AI22M	.09	.15
10	27	5/8	3	27 ER 10API RD 3M	AE27M	27 IR 10API RD 3M	AI27M	.15	.24
8	27	5/8	2	27 ER 8API RD 2M	AE27M	27 IR 8API RD 2M	AI27M	.12	.18

Order example: 27 IR 10 API RD 3M MXC

For recommended number of passes see page A04-4

For carbide grade and cutting speed see page A04-2 and 3

OIL Threads

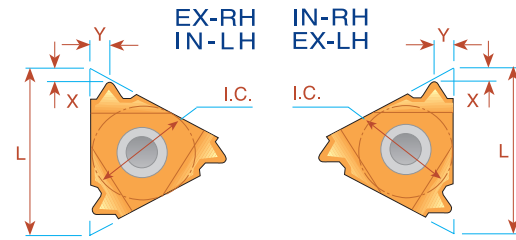
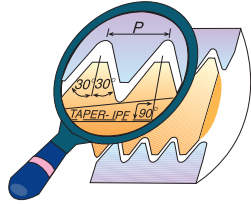

V-0.040

Pitch TPI	L mm	I.C.	Taper IPF	EXTERNAL Ordering Code Right Hand	INTERNAL Ordering Code Right Hand	X	Y	Connection No. or Size
5	22	1/2	3	22 ER 5 API 403	22 IR 5 API 403	.07	.10	2 3/8-4 1/2 REG

(1) V-0.038R

Pitch TPI	L mm	I.C.	Taper IPF	EXTERNAL Ordering Code Right Hand	INTERNAL Ordering Code Right Hand	X	Y	Connection No. or Size
4	27	5/8	2	27 ER 4 API 382	27 IR 4 API 382	.08	.08	NC23-NC50
4	27	5/8	3	27 ER 4 API 383	27 IR 4 API 383	.08	.11	NC56-NC77
4	22	1/2	2	22 ER 4 API 382	22 IR 4 API 382	.08	.10	NC23-NC50
4	22	1/2	3	22 ER 4 API 383	22 IR 4 API 383	.08	.10	NC56-NC77

Order example: 27 ER 4 API 383 MXC

(1) V-0.050

Pitch TPI	L mm	I.C.	Taper IPF	EXTERNAL Ordering Code Right Hand	INTERNAL Ordering Code Right Hand	X	Y	Connection No. or Size
4	27	5/8	2	27 ER 4 API 502	27 IR 4 API 502	.08	.12	65/8 REG
4	27	5/8	3	27 ER 4 API 503	27 IR 4 API 503	.08	.12	5 1/2, 7 5/8, 8 5/8 REG
4	22	1/2	2	22 ER 4 API 502	22 IR 4 API 502	.075	.11	65/8 REG
4	22	1/2	3	22 ER 4 API 503	22 IR 4 API 503	.075	.11	5 1/2, 7 5/8, 8 5/8 REG

Order example: 22 ER 4 API 502 BMA

V-0.055

Macaroni Tubing (MT)

American Macaroni Tubing (AMT)

American Mining Macaroni Tubing (AMMT)

Pitch TPI	L mm	I.C.	Taper IPF	EXTERNAL Ordering Code Right Hand	INTERNAL Ordering Code Right Hand	X	Y	Connection No. or Size
6	22	1/2	1.5	22 ER 6 API 551.5	-	.08	.07	NC10,NC12,NC13,NC16
6	16	3/8	1.5	-	16 IR 6 API 551.5	.08	.07	NC10,NC12,NC13 *
6	22	1/2	1.5	-	22 IR 6 API 551.5	.08	.07	NC16 **

* For NC10,NC12 use holder SIR062516CB
For NC13 use holders SIR0750P16/SIR0750P16B/SIR0750S16CB

** For NC16 use holder SIR1000R22

For Carbide Grade and Cutting Speed see page A04-2 and 3

Thread Turning Inserts

OIL Threads Extreme - Line Casing

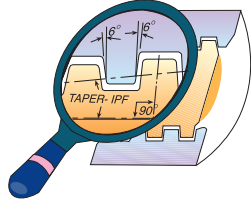

Pitch TPI	L mm	I.C.	Taper IPF	EXTERNAL	INTERNAL	X	Y	Connection No. or Size
				Ordering Code Right Hand	Ordering Code Right Hand			
6	22	1/2	1.50	22 ER 6 EL 1.5	22 IR 6 EL 1.5	.07	.07	5-7 5/8
5	22	1/2	1.25	22 ER 5 EL 1.25	22 IR 5 EL 1.25	.09	.09	8 5/8-10 3/4

Buttress Casing

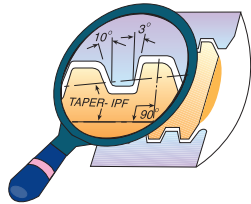

Pitch TPI	L mm	I.C.	Taper IPF	EXTERNAL	INTERNAL	X	Y	Connection No. or Size
				Ordering Code Right Hand	Ordering Code Right Hand			
5	22	1/2	.75	22 ER 5 BUT 0.75	22 IR 5 BUT 0.75	.09	.09	4 1/2-13 3/8
5	22	1/2	1.00	22 ER 5 BUT 1.0	22 IR 5 BUT 1.0	.09	.09	16-20

Order example: 22 ER 5 BUT 0.75 MXC

VAM

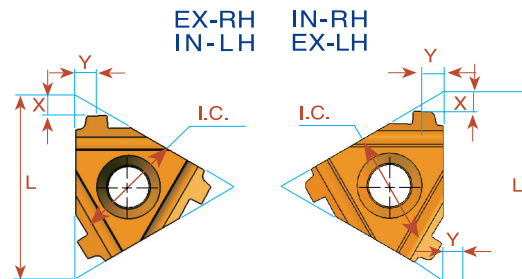
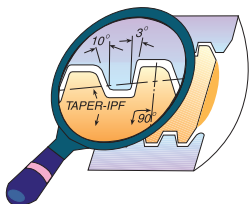

Pitch TPI	L mm	I.C.	Taper IPF	EXTERNAL	X	Y	INTERNAL	X	Y	Connection No. or Size
				Ordering Code Right Hand			Ordering Code Right Hand			
8	16	3/8	.75	16 ER 8 VAM	.07	.07	16 IR 8 VAM	.07	.07	2 3/8 - 2 7/8
6	22	1/2	.75	22 ER 6 VAM	.09	.09	22 IR 6 VAM	.10	.10	3 1/2 - 4 1/2
5	22	1/2	.75	22 ER 5 VAM	.09	.11	22 IR 5 VAM	.09	.10	5 - 13 3/8

For carbide grade and cutting speed see page A04-2 and 3

HUGHES

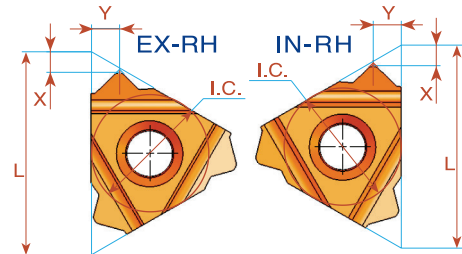
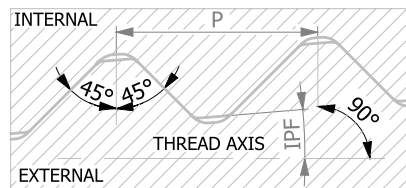

Pitch TPI	L mm	I.C.	Taper IPF	EXTERNAL	INTERNAL	X	Y	Connection No. or Size
				Ordering Code Right Hand	Ordering Code Right Hand			
3.5	27	5/8	2	27 ER 3.5 H 902	27 IR 3.5 H 902	.11	.15	3 1/2 - 6 5/8
3.5	27	5/8	3	27 ER 3.5 H 903	27 IR 3.5 H 903	.11	.15	7 - 8 5/8
3	27	5/8	1.25	27 ER 3 SLH 90	27 IR 3 SLH 90	.13	.18	2 3/8 - 3 1/2

Order example: 27 ER 3.5 H-903 BMA

PAC

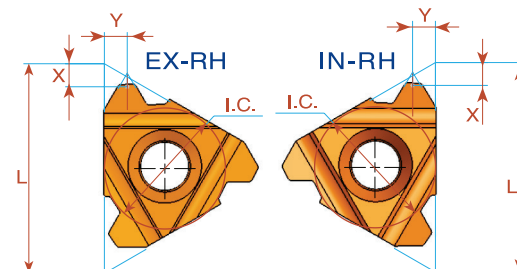
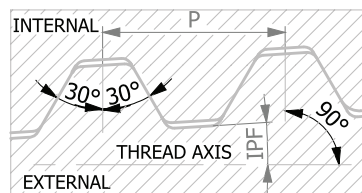

Pitch TPI	L mm	I.C.	Taper IPF	EXTERNAL	INTERNAL	X	Y	Connection No. or Size
				Ordering Code Right Hand	Ordering Code Right Hand			
4	22	1/2	1.5	22 ER 4 PAC	22 IR 4 PAC	.09	.09	2 1/2 - 2 7/8
4	27	5/8	1.5	27 ER 4 PAC	27 IR 4 PAC	.09	.09	2 1/2 - 2 7/8

Order example: 22 ER 4 PAC MXC

Thread Turning Inserts

NPS

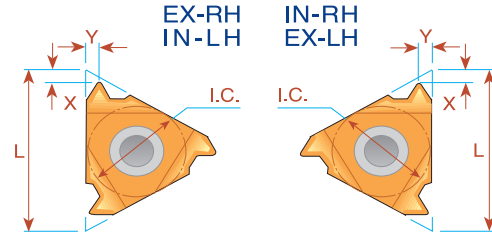
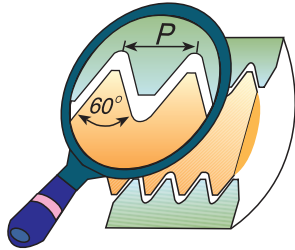

Pitch TPI	L mm	I.C.	EXTERNAL		INTERNAL		X	Y
			Ordering Code Right Hand	Ordering Code Left Hand	Ordering Code Right Hand	Ordering Code Left Hand		
18	16	3/8	16 ER 18 NPS	16 EL 18 NPS	16 IR 18 NPS	16 IL 18 NPS	.03	.04
14	16	3/8	16 ER 14 NPS	16 EL 14 NPS	16 IR 14 NPS	16 IL 14 NPS	.04	.05
11.5	16	3/8	16 ER 11.5 NPS	16 EL 11.5 NPS	16 IR 11.5 NPS	16 IL 11.5 NPS	.04	.06
8	16	3/8	16 ER 8 NPS	16 EL 8 NPS	16 IR 8 NPS	16 IL 8 NPS	.05	.07

Order example: 16 ER 18 NPS BMA

NPSM

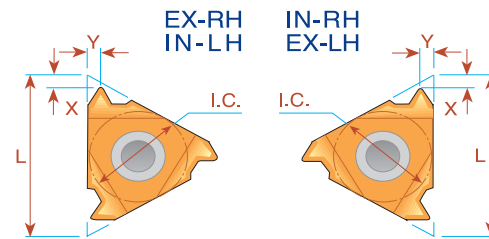
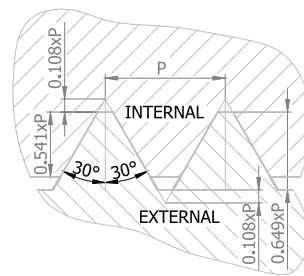

Pitch TPI	L mm	I.C.	EXTERNAL	X	Y	INTERNAL	X	Y
			Ordering Code Right Hand			Ordering Code Right Hand		
18	8	3/16				08 IR 18 NPSM	.03	.03
18	11	1/4				11 IR 18 NPSM	.03	.04
18	16	3/8	16 ER 18 NPSM	.03	.04			
14	16	3/8	16 ER 14 NPSM	.04	.05	16 IR 14 NPSM	.04	.05
11.5	16	3/8	16 ER 11.5 NPSM	.05	.06	16 IR 11.5 NPSM	.05	.06
8	16	3/8	16 ER 8 NPSM	.05	.06	16 IR 8 NPSM	.05	.06

Order example: 16 IR 14 NPSM MXC

For Carbide Grade and Cutting Speed see page A04 - 2-3

Vertical

API

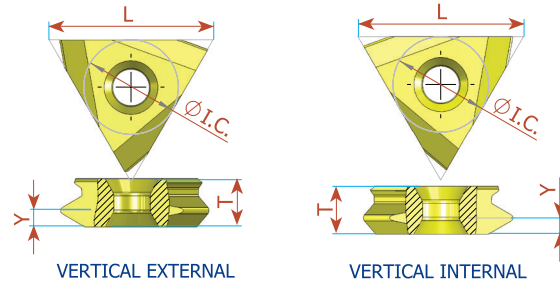
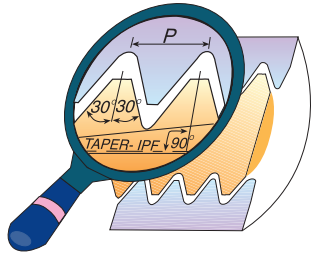

Thread Form	Pitch TPI	L mm	I.C.	Taper IPF	EXTERNAL Ordering Code	Y	T	Connection No. or Size
V-0.040	5	27	5/8	3	TNMB 54 ER 5 API 403	.10	.25	23/8-4 1/2 REG
V-0.038R	4	27	5/8	2	TNMC 55 ER 4 API 382	.11	.31	NC23-NC50
V-0.038R	4	27	5/8	3	TNMC 55 ER 4 API 383	.11	.31	NC56-NC77
V-0.050	4	27	5/8	2	TNMC 55 ER 4 API 502	.12	.31	6 5/8 REG
V-0.050	4	27	5/8	3	TNMC 55 ER 4 API 503	.12	.31	5 1/2, 7 5/8, 8 5/8 REG

Vertical inserts to be used with compatible holders on the market

Order example: TNMC 55 ER 4 API 503 BMA

Thread Form	Pitch TPI	L mm	I.C.	Taper IPF	INTERNAL Ordering Code	Y	T	Connection No. or Size
V-0.040	5	27	5/8	3	TNMB 54 IR 5 API 403	.10	.25	23/8-4 1/2 REG
V-0.038R	4	27	5/8	2	TNMC 55 IR 4 API 382	.11	.31	NC23-NC50
V-0.038R	4	27	5/8	3	TNMC 55 IR 4 API 383	.11	.31	NC56-NC77
V-0.050	4	27	5/8	2	TNMC 55 IR 4 API 502	.12	.31	6 5/8 REG
V-0.050	4	27	5/8	3	TNMC 55 IR 4 API 503	.12	.31	5 1/2, 7 5/8, 8 5/8 REG

Vertical inserts to be used with compatible holders on the market

Order example: TNMC 55 IR 4 API 502 BMA

For carbide grade and cutting speed see page A04-2 and 3

Thread Turning Inserts

Vertical

API Buttress Casing

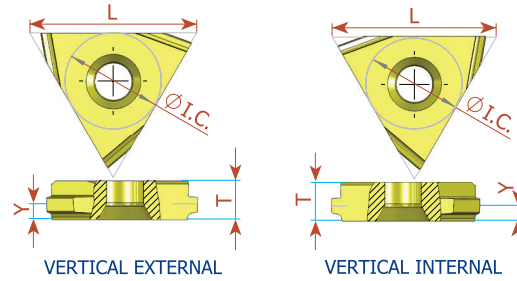
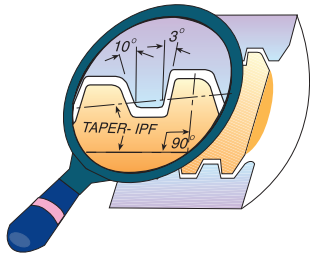

Pitch TPI	L mm	I.C.	Taper IPF	EXTERNAL Ordering Code	Y	T	Connection No. or Size
5	27	5/8	.75	TNMB 54 ER 5 BUT 0.75	.9	.25	4 1/2 - 13 3/8
5	27	5/8	1.00	TNMB 54 ER 5 BUT 1.0	.9	.25	16-20

Order example: TNMB 54 ER 5 BUT 1.0 BMA

Pitch TPI	L mm	I.C.	Taper IPF	INTERNAL Ordering Code	Y	T	Connection No. or Size
5	27	5/8	.75	TNMB 54 IR 5 BUT 0.75	.9	.25	4 1/2 - 13 3/8
5	27	5/8	1.00	TNMB 54 IR 5 BUT 1.0	.9	.25	16-20

Vertical inserts to be used with compatible holders on the market

Order example: TNMB 54 IR 5 BUT 0.75 BMA

For carbide grade and cutting speed see page A04-2 and 3

Vertical

API Round

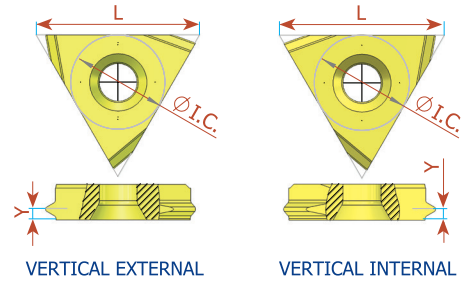
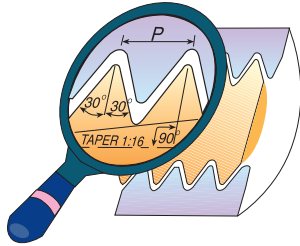

Pitch TPI	L mm	I.C.	Taper IPF	EXTERNAL Ordering Code	Y	T
10	22	1/2	.75	TNMB 43 ER 10 API RD	.057	.19
8	22	1/2	.75	TNMB 43 ER 8 API RD	.065	.19

Order example: TNMB 43 ER 10 API RD BMA

Pitch TPI	L mm	I.C.	Taper IPF	INTERNAL Ordering Code	Y	T
10	22	1/2	.75	TNMB 43 IR 10 API RD	.057	.19
8	22	1/2	.75	TNMB 43 IR 8 API RD	.065	.19

Vertical inserts to be used with compatible holders on the market

Order example: TNMB 43 IR 8 API RD BMA

For carbide grade and cutting speed see page A04-2 and 3

A01-40

Thread Turning Inserts

Chasers

API Round

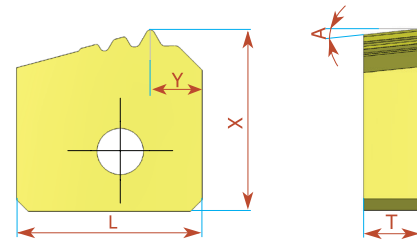

Pitch TPI	L mm	Taper IPF	EXTERNAL Ordering Code	X	Y	T	A	No. of Teeth
10	15.75	.75	15.75 ER 10 API RD 3T	.61	.17	.19	6°	3
8	15.75	.75	15.75 ER 8 API RD 3T	.62	.17	.19	6°	3

Order example: 15.75 ER 10 API RD 3T BMA

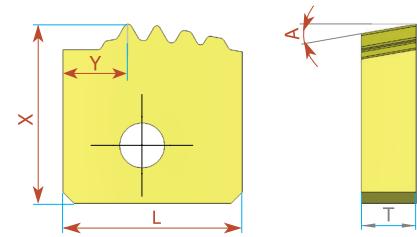

Pitch TPI	L mm	Taper IPF	INTERNAL Ordering Code	X	Y	T	A	No. of Teeth
10	15.75	.75	15.75 IR 10 API RD 4T	.62	.22	.19	10°	4
8	15.875	.75	15.875 IR 8 API RD 4T	.62	.165	.19	10°	4

Chasers to be used with compatible holders on the market

Order example: 15.75 IR 10 API RD 4T BMA

For carbide grade see page A04-2

Chasers

API Buttress Casing

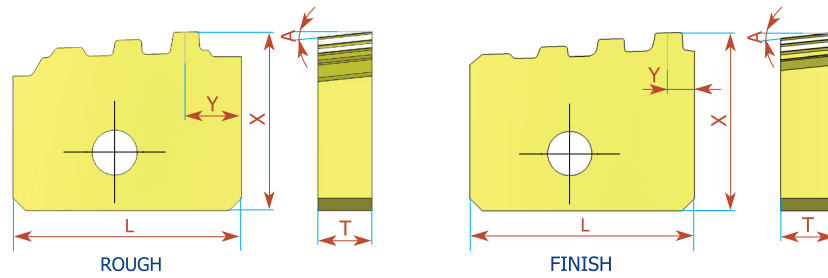

Pitch TPI	L mm	Taper IPF	EXTERNAL Ordering Code	X	Y	T	A	No. of Teeth
5	20	.75	20 ER 5 BUT 0.75R	.62	.19	.19	6°	3
5	20	.75	20 ER 5 BUT 0.75F	.625	.09	.19	6°	4

Order example: 20 ER 5 BUT 0.75F BMA

Chasers

OTTM Buttress Casing

Pitch TPI	L mm	Taper IPF	EXTERNAL Ordering Code	X	Y	T	A	No. of Teeth
5	20	.75	20 ER 5 OTTM 0.75R	.62	.19	.19	6°	3
5	20	.75	20 ER 5 OTTM 0.75F	.625	.09	.19	6°	4

Chasers to be used with compatible holders on the market

Order example: 20 ER 5 OTTM 0.75F BMA

For carbide grade see page A04-2

A01-42

Thread Turning Inserts

Chasers

API Buttress Casing

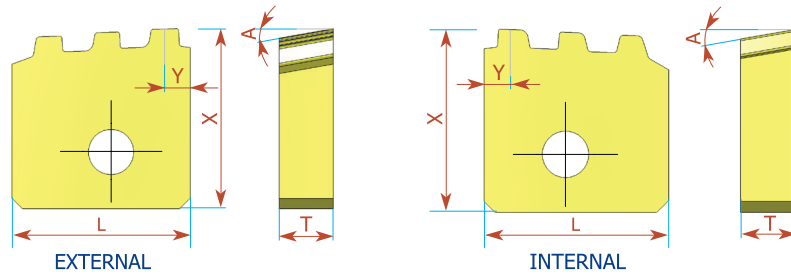

Pitch TPI	L mm	Taper IPF	EXTERNAL Ordering Code	X	Y	T	A	No. of Teeth
5	15.75	.75	15.75 ER 5 BUT 0.75 3T	.625	.09	.19	10°	3

Pitch TPI	L mm	Taper IPF	INTERNAL Ordering Code	X	Y	T	A	No. of Teeth
5	15.875	.75	15.875 IR 5 BUT 0.75 3T	.62	.1	.19	10°	3

Order example: 15.75 ER 5 BUT 0.75 3T BMA

Chasers

OTTM Buttress Casing

Pitch TPI	L mm	Taper IPF	EXTERNAL Ordering Code	X	Y	T	A	No. of Teeth
5	15.75	.75	15.75 ER 5 OTTM 0.75 3T	.62	.12	.19	6°	3

Pitch TPI	L mm	Taper IPF	INTERNAL Ordering Code	X	Y	T	A	No. of Teeth
5	15.875	.75	15.875 IR 5 OTTM 0.75 3T	.625	.10	.19	10°	3

Chasers to be used with compatible holders on the market

Order example: 15.75 ER 5 OTTM 0.75 3T BMA

For carbide grade see page A04-2

Chasers

API Buttress Casing

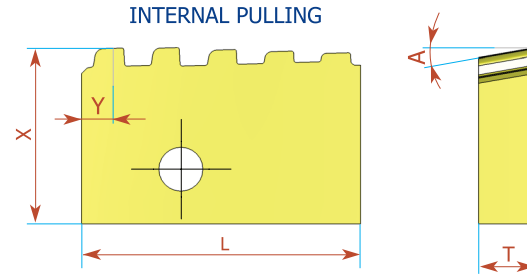

Pitch TPI	L mm	Taper IPF	INTERNAL Ordering Code	X	Y	T	A	No. of Teeth
5	25	.75	25 IRP 5 BUT 0.75 5T	.62	.10	.20	10°	5

Order example: 25 IRP 5 BUT 0.75 5T BMA

Chasers

OTTM Buttress Casing

Pitch TPI	L mm	Taper IPF	INTERNAL Ordering Code	X	Y	T	A	No. of Teeth
5	25	.75	25 IRP 5 OTTM 0.75 5T	.62	.10	.20	10°	5

Chasers to be used with compatible holders on the market

Order example: 25 IRP 5 OTTM 0.75 5T BMA

For carbide grade see page A04-2

Thread Turning Inserts

Large Profile Inserts and Toolholders

- Wide range of pitches
- Rigid clamping
- Tailor made profiles according to customer's request are possible

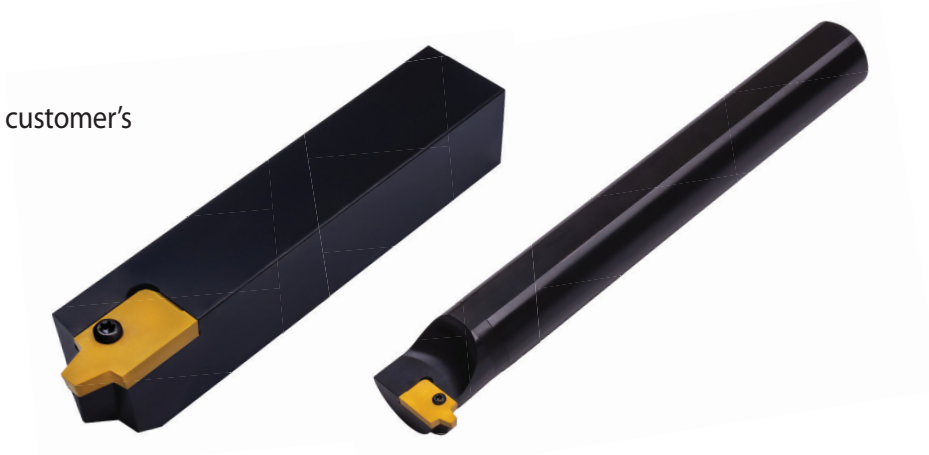

External

Internal

Large profile -Acme

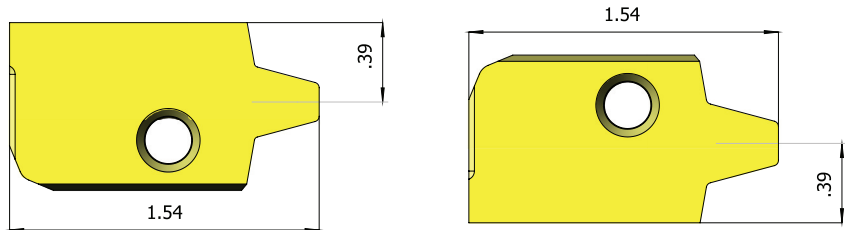

Pitch TPI	Ordering Code EX RH	Holder Code	Ordering Code EX LH	Holder Code	Ordering Code IN RH	Holder Code	Ordering Code IN LH	Holder No.
1 1/2	40 ER 1.5 ACME	AC1	40 EL 1.5 ACME	AC2	40 IR 1.5 ACME	AC6,AC7	40 IL 1.5 ACME	AC5,AC8
1 1/3	40 ER 1.3 ACME	AC1	40 EL 1.3 ACME	AC2	40 IR 1.3 ACME	AC6,AC7	40 IL 1.3 ACME	AC5,AC8
1	40 ER 1 ACME	AC3	40 EL 1 ACME	AC4	40 IR 1 ACME	AC9	40 IL 1 ACME	AC10

Carbide Grade: BMA or MXC

External Holders-Acme

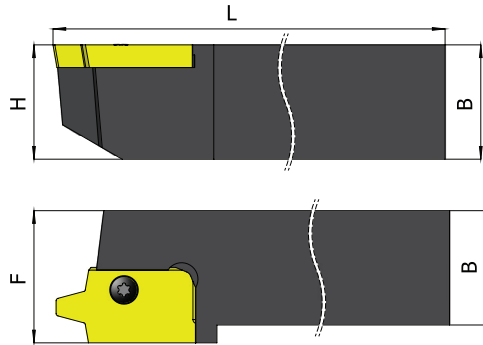

Pitch Range (TPI) 1 1/3-1 1/2 Ordering Code		B=H	L	F	Insert Screw	Torx Screw	Holder No.
EX-RH	SER 1250 P40 AC1	1.25	7	1.25	S40	K40	AC1
EX-LH	SEL 1250 P40 AC2	1.25	7	1.25	S40	K40	AC2

Pitch Range (TPI) 1 Ordering Code		B=H	L	F	Insert Screw	Side Screw	Torx Screw	Holder No.
EX-RH	SER 1250 P40 AC3	1.25	7	1.25	S40	A27	K40	AC3
EX-LH	SEL 1250 P40 AC4	1.25	7	1.25	S40	A27	K40	AC4

Pitch Range (TPI) 1 1/3-1 1/2 Ordering Code		B=H	L	F	Insert Screw	Torx Screw	Holder No.
EX-RH	*SER 1000 M40 AC5	1.00	6	1.25	S40	K40	AC5
EX-LH	*SEL 1000 M40 AC6	1.00	6	1.25	S40	K40	AC6

* toolholders to be used with toolbar provided by the customer

Thread Turning Inserts

Internal Holders-Acme

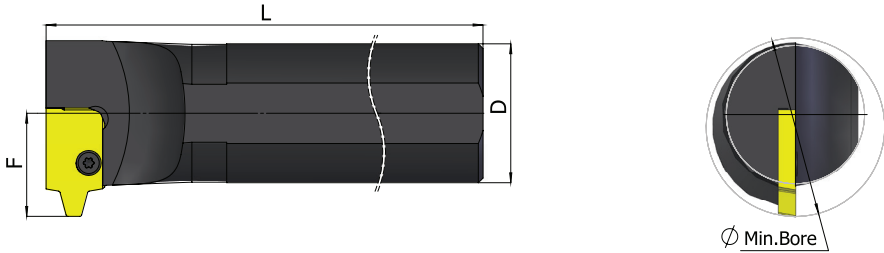

Pitch Range (TPI) 1 1/2-1 1/3 Ordering Code		D	Min Bore Diam.	L	F	Insert Screw	Torx Screw	Holder No.
IN-RH	SIR 2000 V40 AC7	2.00	2.56	16	1.44	S40	K40	AC7
IN-LH	SIL 2000 V40 AC8	2.00	2.56	16	1.44	S40	K40	AC8

Pitch Range (TPI) 1 Ordering Code		D	Min Bore Diam.	L	F	Insert Screw	Side Screw	Torx Screw	Holder No.
IN-RH	SIR 2000 V40 AC9	2.00	2.75	16	1.58	S40	A27	K40	AC9
IN-LH	SIL 2000 V40 AC10	2.00	2.75	16	1.58	S40	A27	K40	AC10

Large profile- Stub Acme

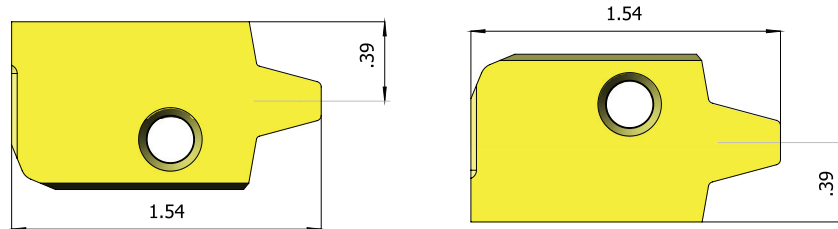

Pitch TPI	Ordering Code EX RH	Holder Code	Ordering Code EX LH	Holder No.	Ordering Code IN RH	Holder Code	Ordering Code IN LH	Holder No.
1 1/2	40 ER 1.5 STACME	SA1	40 EL 1.5 STACME	SA2	40 IR 1.5 STACME	SA6,SA7	40 IL 1.5 STACME	SA5,SA8
1 1/3	40 ER 1.3 STACME	SA1	40 EL 1.3 STACME	SA2	40 IR 1.3 STACME	SA6,SA7	40 IL 1.3 STACME	SA5,SA8
1	40 ER 1 STACME	SA3	40 EL 1 STACME	SA4	40 IR 1 STACME	SA9	40 IL 1 STACME	SA10

Thread Turning Inserts

External Holders- Stub Acme

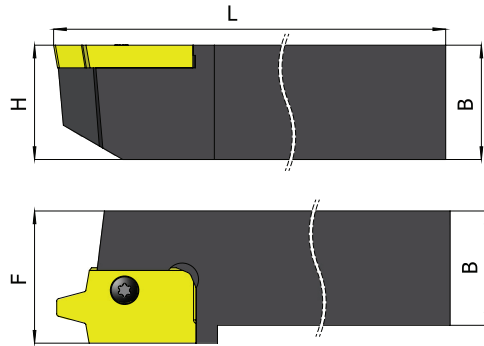

Pitch Range (TPI) 1 1/3 - 1 1/2 Ordering Code		B=H	L	F	Insert Screw	Torx Screw	Holder No.
EX-RH	SER 1250 P40 SA1	1.25	7	1.25	S40	K40	SA1
EX-LH	SEL 1250 P40 SA2	1.25	7	1.25	S40	K40	SA2

Pitch Range (TPI) 1 Ordering Code		B=H	L	F	Insert Screw	Side Screw	Torx Screw	Holder No.
EX-RH	SER 1250 P40R SA3	1.25	7	1.25	S40	A27	K40	SA3
EX-LH	SEL 1250 P40R SA4	1.25	7	1.25	S40	A27	K40	SA4

Pitch Range (TPI) 1 1/3 - 1 1/2 Ordering Code		B=H	L	F	Insert Screw	Torx Screw	Holder No.
EX-RH	*SER 1000 M40 SA5	1.00	6	1.25	S40	K40	SA5
EX-LH	*SEL 1000 M40 SA6	1.00	6	1.25	S40	K40	SA6

* toolholders to be used with toolbar provided by the customer

Internal Holders- Stub Acme

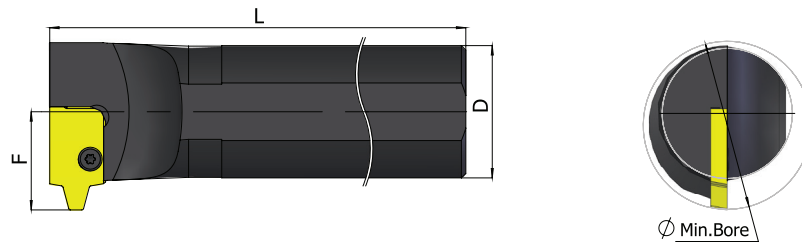

Pitch Range (TPI) 1 1/3-1 1/2 Ordering Code		D	Min Bore Diam.	L	F	Insert Screw	Torx Screw	Holder No.
IN-RH	SIR 2000 V40 SA7	2.00	2.36	16	1.26	S40	K40	SA7
IN-LH	SIL 2000 V40 SA8	2.00	2.36	16	1.26	S40	K40	SA8

Pitch Range (TPI) 1 Ordering Code		D	Min Bore Diam.	L	F	Insert Screw	Side Screw	Torx Screw	Holder No.
IN-RH	SIR 2000 V40R SA9	2.00	2.44	16	1.34	S40	A27	K40	SA9
IN-LH	SIL 2000 V40R SA10	2.00	2.44	16	1.34	S40	A27	K40	SA10

A01-50

Thread Turning Inserts

Large profile -American Buttress

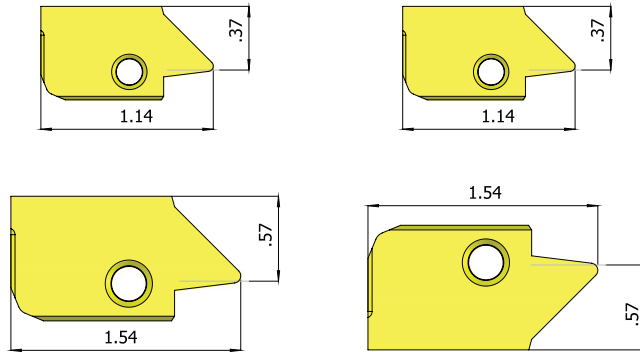

Pitch TPI	Ordering Code EX RH	Holder No.	Ordering Code EX LH	Holder Code	Ordering Code IN RH	Holder No.	Ordering Code IN LH	Holder No.
2 1/2	30 ER 2.5 ABUT	AB1,AB3	30 EL 2.5 ABUT	AB2,AB4	30 IR 2.5 ABUT	AB11	30 IL 2.5 ABUT	AB12
2	40 ER 2 ABUT	AB5,AB7	40 EL 2 ABUT	AB6,AB8	40 IR 2 ABUT	AB13, AB15	40 IL 2 ABUT	AB14, AB16
1 1/2	40 ER 1.5 ABUT	AB9	40 EL 1.5 ABUT	AB10	40 IR 1.5 ABUT	AB17, AB19	40 IL 1.5 ABUT	AB18, AB20
1 1/4	40 ER 1.25 ABUT	AB9	40 EL 1.25 ABUT	AB10	40 IR 1.25 ABUT	AB17, AB19	40 IL 1.25 ABUT	AB18, AB20

External Holders- American Buttress

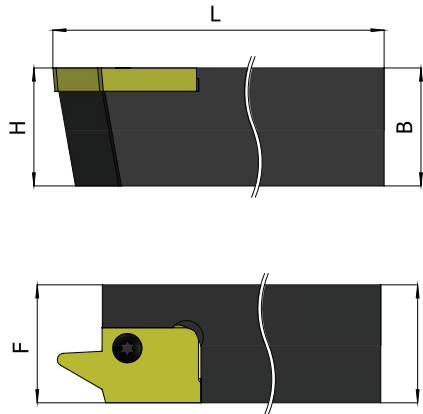

Pitch Range (TPI) 2 1/2 Ordering Code		B=H	L	F	Insert Screw	Torx Screw	Holder No.
EX-RH	SER 1000 P30 AB1	1.00	6	1.00	S30	K30	AB1
EX-LH	SEL 1000 P30 AB2	1.00	6	1.00	S30	K30	AB2
EX-RH	SER 1250 P30 AB3	1.25	7	1.25	S30	K30	AB3
EX-LH	SEL 1250 P30 AB4	1.25	7	1.25	S30	K30	AB4

Pitch Range (TPI) 2 Ordering Code		B=H	L	F	Insert Screw	Torx Screw	Holder No.
EX-RH	SER 1000 M40 AB5	1.00	6	1.25	S40	K40	AB5
EX-LH	SEL 1000 M40 AB6	1.00	6	1.25	S40	K40	AB6
EX-RH	SER 1250 P40 AB7	1.25	7	1.25	S40	K40	AB7
EX-LH	SEL 1250 P40 AB8	1.25	7	1.25	S40	K40	AB8

Pitch Range (TPI) 1 1/4 - 1 1/2 Ordering Code		B=H	L	F	Insert Screw	Side Screw	Torx Screw	Holder No.
EX-RH	SER 1250 P40 AB9	1.25	7	1.25	S40	A27	K40	AB9
EX-LH	SEL 1250 P40 AB10	1.25	7	1.25	S40	A27	K40	AB10

Thread Turning Inserts

Internal Holders- American Buttress

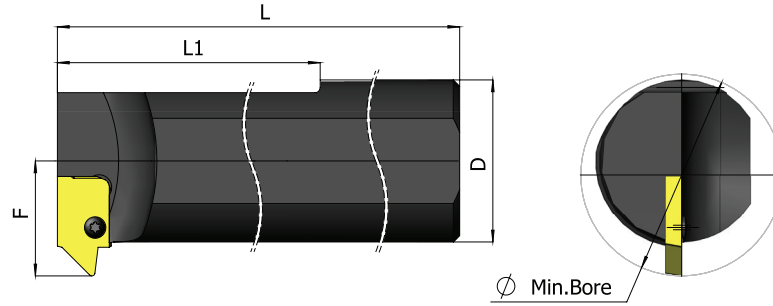

Pitch Range (TPI) 2 1/2 Ordering Code		D	Min Bore Diam.	L	L1	F	Insert Screw	Torx Screw	Holder No.
IN-RH	SIR 1250 S30 AB11	1.25	1.57	10	4.72	24	S30	K30	AB11
IN-LH	SIL 1250 S30 AB12	1.25	1.57	10	4.72	24	S30	K30	AB12

Pitch Range (TPI) 2 Ordering Code		D	Min Bore Diam.	L	F	Insert Screw	Torx Screw	Holder No.
IN-RH	SIR 1500 T40 AB13	1.5	1.97	12	1.1	S40	K40	AB13
IN-LH	SIL 1500 T40 AB14	1.5	1.97	12	1.1	S40	K40	AB14
IN-RH	SIR 2000 U40 AB15	2.0	2.56	14	1.38	S40	K40	AB15
IN-LH	SIL 2000 U40 AB16	2.0	2.56	14	1.38	S40	K40	AB16

Pitch Range (TPI) 1.5-1.25 Ordering Code		D	Min Bore Diam.	L	F	Insert Screw	Side Screw	Torx Screw	Holder No.
IN-RH	SIR 2000 U40 AB17	2.0	2.76	14	1.5	S40	A27	K40	AB17
IN-LH	SIL 2000 U40 AB18	2.0	2.76	14	1.5	S40	A27	K40	AB18
IN-RH	SIR 2500 V40 AB19	2.5	3.23	16	1.77	S40	A27	K40	AB19
IN-LH	SIL 2500 V40 AB20	2.5	3.23	16	1.77	S40	A27	K40	AB20